



**City of Biddeford  
Finance Committee**

November 6, 2025 at 5:00 PM  
City Hall Council Chambers & Zoom

[Click to Join Zoom Meeting Online](#)

Or call in by phone: +1 312 626 6799

Meeting ID: 938 7187 2309

Passcode:991479

1. Call to Order
2. Approval of Minutes
  - 2.a Meeting Minutes 20.21.25
3. Signing of the Expenditure Warrant
4. Discussion/Approval
  - 4.a 2025.153 Approval / Fire Department Marine Unit Bid and Sale/Auction of two (2) Marine Units
5. Other Business
6. Adjourn

*City of Biddeford*  
**Finance Committee**  
**October 21, 2025 5:00 PM Council Chambers & Zoom**

Councilor Beaupre: Present  
Councilor Lessard: Late  
Councilor LaFountain: Late  
Grohman: Present

**1. Call to order**

**2. Approval of the Minutes**

Approved

Lessard - First  
Beaupre - Second

Unanimous

**3. Signing of the expenditure warrant**

None

**4. Discussion/Approval**

**4.a Quarterly Update – Fire Department Maine EMS Sustainability Grant #2**

Chief Best – There have been no expenditures in this quarter. Finance Committee approved Lucas CPR which will be in next quarter. Use some of the funds to send employee to paramedic school roughly \$12,500 and other trainings. Also, capital upgrades for training classrooms. They have until March 2026 all spent.

**Grohman first**  
**Lessard Second**

**4.b Year to Date Budget Report 10.16.25**

Director Matherne – Gave a run down of the YTD expense report. Lessard asked for a few items to be added to the report.

## **5. Other Business**

### **5.a Training Session Purchasing Policy Ordinance**

City Manager - Policy committee looked at higher level of approvals and thresholds where they would go to Finance Committee or Council meeting.

Phinney – Present the Procurement Process Flow Chart. He went through the different thresholds and authorizations.

Lessard – Bid process will stay the same.

Motion to adjourn – LaFountain 5:38

Second: Beaupre

Unanimous



## Finance Committee

---

**Meeting Date:** November 6, 2025

**Meeting Time:** 5:00 PM

**Agenda Item** 4.a

**No:**

**Item** 2025.153 Approval / Fire Department Marine Unit Bid and Sale/Auction of two

**Description:** (2) Marine Units

**Submitted By:** Lawrence D. Best, Fire Chief

### **Key Terms:**

Approval / Fire Department Marine Unit Bid and Sale/Auction of two (2) Marine Units

### **Executive Summary:**

#### **Part 1 — Bid Award:**

Pursuant to the current City Purchasing Policy Sec. 2-348 (g) (3)... Bid results less than \$50,000.00 and over the budgeted amount, or not the lowest bid, will be submitted to the Finance Committee of the City Council for acceptance and awarding of the contract to the successful bidder. Contracts that exceed \$50,000.00 shall be approved by the City Council prior to signing and executing said contract. It should be noted that the Council approved updates to the City Purchasing Policy which do not take effect until November 7, 2025.

In August of this year, the Fire Department sent out a Request for Bids (RFB) for a new 19'-22' Center Console Rigid Hull Inflatable Type Marine Unit. The bids closed on September 24, 2025 at 4:00pm. The goal of this project is to replace the two (2) Fire Department Marine Units with one (1) Marine Unit that will be housed on a trailer and can be deployed for rescue operations both above and below the dam.

There were two (2) companies that submitted bids for a total of three (3) boats ranging in cost from \$100,983.00 to \$132,937.00. The first bid was from Ribcraft USA, LLC in the amount of \$100,983.00 for a Ribcraft 5.85, 19'4" boat with a 115HP motor. The second bid was from Ribcraft USA, LLC in the amount of \$132,937.00 for a Ribcraft 6.5, 21'5" boat with a 150HP motor. The third bid was from Zodiac North America in the amount of \$128,500.00 for a Zodiac Milpro SRR 650, 21'11" boat with a 150HP Motor.

After reviewing the bids and specifications for each boat, it was determined that the Zodiac SRR 650 boat is the unit that best fits the Fire Department's needs, and is the recommendation for award of the bid. The method of tube attachment to the hull is a better method; it has a slightly wider beam, and it includes all the electronics which Ribcraft did not. Because Ribcraft did not include the electronics, this would be an added expense to purchase and install after either of the Ribcraft boats were received.

The Zodiac SRR 650 bid cost is \$128,500.00, which is \$3,500.00 more than the available funds for this CIP purchase.

### **Part 2 — Approval To Sell/Auction:**

Per City Purchasing Policy Sec. 2-347, Responsibility of Departments (2) (2c), .... Sell, trade or otherwise dispose of surplus supplies belonging to the City; assist the departments of the City with the establishment and maintenance of programs for specification development, contract administration and product inspection and acceptance and coordination of supplies and service purchases.

The Fire Department is requesting approval to sell/auction two (2) Marine Units.

1. 1963 Crestliner 16' aluminum boat with 25hp outboard motor and trailer, hull # SN OR668866, Model# 1A2531EK; estimated value \$3,365.00 — \$3,790.00.

2. 1996 Boston Whaler 20' boat with 125hp outboard motor and trailer, hull # SN 2B231909, Model # 1225P83BD; estimated value \$19,000.00 — \$21,515.00.

### **Detailed Review:**

#### **The Fire Department is requesting approval to award the bid for a new Marine Unit**

In August of this year, the Fire Department sent out an RFB for a new 19'-22' Center Console Rigid Hull Inflatable Type Marine Unit. The bids closed on September 24, 2025, at 4:00pm. The goal of this project is to replace the two (2) Fire Department Marine Units with one (1) Marine Unit that will be housed on a trailer and can be deployed for rescue operations both above and below the dam.

There were two (2) companies that submitted bids for a total of three (3) boats ranging in cost from \$100,983.00 to \$132,937.00. The first bid was from Ribcraft USA, LLC in the amount of \$100,983.00 for a Ribcraft 5.85, 19'4" boat with a 115HP motor. The second bid was from Ribcraft USA, LLC in the amount of \$132,937.00 for a Ribcraft 6.5, 21'5" boat with a 150HP motor. The third bid was from Zodiac North America Inc. in the amount of \$128,500.00 for a Zodiac Milpro SRR 650, 21'11" boat with a 150HP Motor.

After reviewing the bids and specs for each boat, it was determined the Zodiac SRR 650 boat is

the unit that best fits the Fire Department's needs and is the recommendation for award of the bid. The method of tube attachment to the hull is a better method; it has a slightly wider beam, and it includes all the electronics which Ribcraft did not. Because Ribcraft did not include the electronics, this would be an added expense to purchase and install after either of the Ribcraft boats were received.

The Zodiac SRR 650 bid cost is \$128,500.00, which is \$3,500.00 more than the available funds for this CIP purchase.

**The Fire Department is also requesting approval to sell/auction two (2) Marine Units...**

1. 1963 Crestliner 16' aluminum boat with 25hp outboard motor and trailer, hull # SN OR668866, Model# 1A2531EK; estimated value \$3,365.00 — \$3,790.00.

2. 1996 Boston Whaler 20' boat with 125hp outboard motor and trailer, hull # SN 2B231909, Model # 1225P83BD; estimated value \$19,000.00 — \$21,515.00.

**Background/History:**

Through the FY26 CIP process, the Fire Department requested funding to replace the existing 1963, 62-year-old aluminum boat that does not meet the safety and rescue needs for our current water conditions. The 1963 aluminum boat is not stable enough or designed to allow rescuers the ability to pull patients/victims from the water into the boat. On average, the BFD responds to 12 incidents annually that necessitate the response of a marine unit. The estimated budget cost obtained in 2024 for this project was \$80,000.00. This CIP request was approved on recommendation by the Acting City Manager. The Capital Projects Committee met on June 11<sup>th</sup> to review and make allocation recommendations for the FY 26 CIP and again on August 13<sup>th</sup> to review and approve the allocation of the balance of the funds. On September 2<sup>nd</sup>, the City Council voted to approve the recommendations made by the Capital Projects Committee which included this new Marine Unit.

After the budget process was completed, the Fire Department successfully submitted and received a grant from the Stephen and Tabitha King Foundation in the amount of \$45,000.00 to help with funding for this project. This grant of \$45,000.00 was accepted by the City Council on July 15<sup>th</sup>. The funding source for the \$80,000.00 that was included in the budgeting process was decided to be from the Mooring Fund Surplus (Fund 202). The combined total available funds are \$125,000.00.

In addition to these available funds, the Fire Department will be requesting approval from the City Council to auction/sell the current 1963 Aluminum Marine 202 unit and trailer, which is valued at an estimated \$3,365.00 - \$3,790.00 and a second Marine unit, which is a 1996 20-foot Boston Whaler and trailer which is valued at an estimated \$19,000 - \$21,515.00. The goal would be to have funds from the sale of these boats cover the additional \$3,500.00 cost above

the \$125,000.00 available with the remainder of the sale funds going back into the Mooring Fund Surplus (Fund 202) or other account as deemed appropriate by the City Council.

The June 11<sup>th</sup> meeting materials, including meeting video and supporting documentation, are available via this link ( [Capital Projects/Operations Committee \(LIVE\) • Agendas and Minutes - City of Biddeford, ME • CivicClerk](#) ). The August 13th meeting materials, including meeting video and supporting documentation, are available via this link ( [Capital Projects / Operations Committee Meeting \(Live\) • Agendas and Minutes - City of Biddeford, ME • CivicClerk](#) ). The City Council approved this CIP project on September 2, 2025, ( [City Council Meeting \(Live\) • Agendas and Minutes - City of Biddeford, ME • CivicClerk](#) ).

An earlier Capital Projects / Operations Committee Meeting occurred in May to present the FY26 CIP requests. The May meeting materials, including meeting video and supporting documentation, are available via this link ( [Capital Projects / Operations Committee Meeting \(Live\) • Agendas and Minutes - City of Biddeford, ME • CivicClerk](#) ).

**Funding Source:**

A total of \$128,500.00 is requested for this CIP project. \$80,000.00 will come from the Mooring Fund Surplus (Fund 202), which has a balance of \$131,889.17 for this CIP project through the FY26 CIP Budget process. \$45,000.00 will come from the Stephen and Tabitha King foundation, and it is requested that \$3,500.00 be funded from the Mooring Fund Surplus (Fund 202) and be replenished with funds from the sale of the two (2) current FD Marine Units.

**Staff Recommendation:**

Staff recommends the approval of the bid to Zodiac of North America Inc. for the SRR 650 Marine Unit at the bid cost of \$128,500.00 and to approve the sale/auction the two (2) Marine units; 1. 1963 Crestliner 16' aluminum boat with 25hp outboard motor and trailer, hull # SN OR668866, Model# 1A2531EK; estimated value \$3,365.00 — \$3,790.00. 2. 1996 Boston Whaler 20' boat with 125hp outboard motor and trailer, hull # SN 2B231909, Model # 1225P83BD; estimated value \$19,000.00 — \$21,515.00.

**Next Steps:**

Upon approval, staff will begin the process to advertise and sell/auction the two (2) Marine Units.

**Attachments:**

1. Order 2025.153 Approval to Award Bid and to Sell Two (2) Fire Department Marine Units
2. Bid #1 Ribcraft option A
3. Bid #2 Ribcraft option B
4. Bid #3 Zodiac
5. FY26 Capital Projects - Operations Committee Recommendation No. 1 Summary
6. FY26 Captial Approval Document

7. FY26 CIP Marine Unit 202 Replacement

# City of Biddeford



**2025.153**            **IN BOARD OF CITY COUNCIL.....November 6, 2025,**  
**BE IT ORDERED** that the Biddeford City Council hereby approves the bid award to Zodiac of North America Inc. for the SRR 650 Marine Unit at the bid cost of \$128,500.00. Be it further ordered that the Council approves the sale/auction of the two (2) Fire Department Marine Units, a 1963 16 foot aluminum boat with a 25HP outboard motor and trailer, hull #SN 0R668866, Model# 1A2531EK and a 1996 Boston Whaler boat with a 125HP outboard motor and trailer, hull #SN 2B231909, Model # 1225P83BD. The funds from the sale/auction of these two (2) units will be deposited into the Mooring Fund Surplus account (Fund 202) to replenish funds that were used for the purchase of the new Fire Department Marine Unit.

Attest by: \_\_\_\_\_



RIBCRAFT USA, LLC  
88 Hoods Lane, PO Box 463  
Marblehead, MA 01945  
t. 781.639.9065 f. 781.639.9062  
toll free. 866 RIBS USA  
www.ribcraftusa.com

COPY

**PROPOSAL OPTION A**

September 22, 2025

City of Biddeford Fire Department  
152 Alfred Street  
Biddeford, ME 04005  
Attn: Assistant

**RE: RFP – Supply and Delivery of a Fire Department Emergency Response Boat**

On behalf of RIBCRAFT USA, LLC, I am pleased to provide you with the following proposal for one (1) RIBCRAFT 5.85 with all specified options and equipment in response to RFP – Supply and Delivery of a Fire Department Emergency Response Boat, dated August 20, 2025.

The RIBCRAFT 5.85 is built to the highest commercial grade specifications and standards resulting in remarkably solid, well performing, and safe rigid inflatable boat (RIB). As the manufacturer of the above stated boat, this boat meets the requirements put forth by the City of Biddeford Fire Department.

Please find enclosed the following documents:

- Completed & Signed Bid Documents
- Bidder Response Supplement
- Detailed RIBCRAFT Quote
- RIBCRAFT Brochure

With safety and reliability at the core of all RIBCRAFT designs, the RIBCRAFT 5.85 features a deep V hull, full-length spray rails, high bow sheer, and a heavy-duty multi chambered Hypalon tube. To insure the utmost in durability and strength all hulls are solid fiberglass with an internal composite stringer system.

For almost twenty-five years, safety and rescue professionals have come to expect the most in quality, dependability and service from RIBCRAFT and our line of professional grade rigid inflatable boats (RIBs). Constructed by skilled craftsmen in the United States (Massachusetts), every boat is built with the understanding that it will receive hard, offshore 24/7 commercial use.

Many thanks in advance for your time and consideration.

*Kelly Marie*

RIBCRAFT USA, LLC

**ATTACHMENT A:**

**REFERENCE FORM**

Bidder: RIBCRAFT USA, LLC

RFB Title: The Supply, and Delivery of a Fire Department Emergency Response Boat

**Bidder must provide references for:**

All current contracts under which the vendor's equipment has been operational for at least two years.

Reference: Kennebunk Harbormaster Contact: Jamie Houtz  
Address: 1 Summer Street Kennebunk, ME 04043 Phone: 207-985-7976  
Fax: harbormaster@kennebunkmaine.us

Description and date(s) of supplies or services provided: RIBCRAFT built and delivered a RIBCRAFT 5.85 to the Kennebunk Harbormaster in March of 2023. The boat had a similar layout with a center console, T-top, red tube with boarding wear patches and grab handles, and a 115HP outboard.

Reference: Boston Fire Department Contact: Ed McCarthy  
Address: 115 South Hampton Street Boston, MA 02118 Phone: 617-828-3978  
Fax: edward.mccarthy@boston.gov

Description and date(s) of supplies or services provided: RIBCRAFT built and delivered a RIBCRAFT 5.85 to the Boston Fire Department in April of 2020. RIBCRAFT worked with the Chief to understand their operational requirements and built a boat that meets all of their demands - a reliable response boat to be used on the Charles River and Boston Harbor.

Reference: Maine Marine Patrol Contact: Steve Ingram  
Address: 21 State House Station Augusta, ME 04333 Phone: 207-624-7338  
Fax: steve.ingram@maine.gov

Description and date(s) of supplies or services provided: RIBCRAFT has built and delivered numerous RIBCRAFT 4.8 boats to the Maine Marine Patrol. The RIBs are onboard MMP's larger patrol boats and a favorite among the officers and the most used boats in the fleet.

*attach additional sheets if necessary*

**ATTACHMENT B: BID FORM**

The undersigned BIDDER proposes and agrees, if the Bid is accepted to enter into an Agreement with the City, to complete all work as specified or indicated in the "REQUEST TO BID: for the supply, delivery of a FIRE DEPARTMENT EMERGENCY RESPONSE BOAT and TRAILER, exactly as outlined and detailed in this bid.

**Bid Price:** One hundred thousand nine hundred eighty three dollars (\$ 100,983.00 )

BIDDER accepts all the terms and conditions of the Instructions to Bidders.

In submitting this Bid, BIDDER represents, as more fully set forth in the Agreement, that: BIDDER has examined copies of all the Contract Documents **and of the following Addenda:**

Date	N/A	Number	N/A
Date		Number	

BIDDER shall submit an itemized list of costs including vessel accessories, attachments, trailer and delivery as outlined in this bid.

BIDDER agrees that Prevailing Wage Rates if applicable will be paid for the appropriate classification of work.

The undersigned certifies under penalties of perjury that this Bid is in all respects bona fide, fair and made without collusion or fraud with any other person. As used in this paragraph, the word "person" shall mean any natural person, joint venture, partnership, corporation or other business or legal entity.

Signed:  Print Name: Kelly Marie

Company: RIBCRAFT USA, LLC

Business Address: 88 Hoods Lane  
Marblehead, MA 01945

Email: kmarie@ribcraftusa.com

FAX:



? ~~6000~~  
Ceelvanize Trailer?  
115 hp

RIBCRAFT USA, LLC  
88 Hoods Lane, PO Box 463  
Marblehead, MA 01945  
t. 781.639.9065 f. 781.639.9062  
toll free. 866 RIBS USA  
www.ribcraftusa.com

**PROPOSAL OPTION A**

**BIDDER RESPONSE SUPPLEMENT**

Proposal for RFP – Supply and Delivery of a Fire Department Emergency Response Boat

**CERTIFICATIONS / MANUFACTURERS EXPERIENCE:**

RIBCRAFT hereby certifies that the proposed 2026 19’4” RIBCRAFT 5.85 rigid inflatable boat and additional items related hereto are compliant with the technical specifications contained in the Invitation For Bid dated August 20, 2025 for RFP – Fire Department Emergency Response Boat. Such compliancy includes, but is not limited to, design, construction, performance, durability, and warranty except where indicated.

The proposed RIBCRAFT 5.85 Rigid Inflatable Boat is designed, built and tested in accordance with the American Boat & Yacht Council’s quality technical practices and engineering standards for the design, construction and safety of small craft. The boat will be equipped and configured as specified in the bid package and shall meet all necessary requirements.

**EXPERIENCE / CREDENTIALS**

Headquartered in Marblehead, Massachusetts, RIBCRAFT designs and builds safe, durable, performance oriented rigid inflatable boats (RIBs) that fulfill the most demanding professional applications. For nearly 25 years, RIBCRAFT has built professional grade RIBs and inflatables in the United States for military applications, law enforcement agencies, safety professionals, and private industry. The RIBCRAFT model line ranges in size from 14 to 42 feet.

Since inception in 2001, RIBCRAFT USA, LLC has developed one of the strongest and most recognized brands in the rigid inflatable boat market. RIBCRAFT focuses on government and commercial users who comprise 85% of the company’s revenues.

Every RIBCRAFT is built to customer-defined specifications following a detailed design process, including not only powering options and color schemes but also general arrangement, electrical packages, and myriad customer-specific equipment configurations. The RIBCRAFT team is comprised of marine professionals experienced in and passionate about designing and building RIBs that meet and exceed customer expectations and mission requirements.

Incorporating a conventional solid fiberglass hull with an inflatable tube for increased buoyancy, stability, and overall performance RIBCRAFT builds professional grade rigid

inflatable boats ranging in size from 14' to 42' that fulfill a variety of missions from patrol and rescue to interdiction and military operations. Every boat is built to industry recognized standards featuring commercial grade fiberglass hulls and heavy duty multi-chambered air tubes. Designed for professional applications, a RIBCRAFT RIB with a deep V hull and heavy duty tube provides unparalleled performance regardless of the sea conditions.

RIBCRAFT supplies the United States Navy with the standard 7 Meter shipboard RIB and the 11 Meter Expeditionary RIB. Additionally, RIBCRAFT supplies commercial grade boats to the US Air Force, US Fish & Wildlife, state and local law enforcement agencies, fire departments, and industry (profit & non-profit).

**REFERENCES:**

As requested, RIBCRAFT has built Fire and Rescue Boats for the following agencies in recent years:

Kennebunk Harbormaster  
1 Summer Street  
Kennebunk, ME 04043  
Jamie Houtz  
harbormaster@kennebunkmaine.us  
207-985-7976

Boston Fire Department  
115 South Hampton Street  
Boston, MA 02118  
Ed McCarthy  
Edward.mccarthy@boston.gov  
617-828-3978

Maine Marine Patrol  
21 State House Station  
Augusta, ME 04333  
Steve Ingram  
Steve.ingram@maine.gov  
207-624-7338

Portsmouth Fire Department  
170 Court Street  
Portsmouth, NH 03801  
John Goodwin  
jwgoodwin@cityofportsmouth.com  
603-944-7920

## BOAT SPECIFICATIONS:

Based on the invitation for bid and the estimated referenced value, RIBCRAFT hereby proposes the RIBCRAFT 5.85 as a rescue boat for the City of Biddeford. The RIBCRAFT 5.85 Rigid Inflatable Boat specifications are as indicated below and as illustrated in the attached RIBCRAFT 5.85 Specification Marketing Sheet.

LOA:	19'4"
Beam:	8'
Internal Length:	14'9"
Internal Beam:	5'1"
Weight:	1,200 – 1,700 lbs (without engine)

The proposed 2026 RIBCRAFT 5.85 features a commercial grade fiberglass deep V hull with a heavy duty 1670 dtx red Hypalon tube with five air chambers each with pressure relief valves, a pair of boarding wear patches and a pair of tube grab handles. The boat is configured with a center console with front bench seat, full size windscreen, leaning post with backrest, footrest and storage, a t-top with aluminum hard top, antenna arch with integrated dive ladder, LED navigation and flood lights, a 115HP Mercury four stroke outboard engine, a bunk trailer and all other features and options as specified in the Scope of Services.

Please see the enclosed Detailed Quote and Drawing for the quoted configuration which outlines all features and options included.

The RIBCRAFT 5.85 meets the requirements and specifications for the boat and engine as outlined in the RFP August 20, 2025.

### Length/Measurements

The RIBCRAFT 5.85 at 19'4" as proposed is fully compliant with the specifications as noted above and in the Scope of Services.

### Hull Construction

The RIBCRAFT 5.85 as proposed is fully compliant with the features outlined. Featuring a heavy duty commercial grade solid fiberglass (FRP) hull, the 5.85 also includes an internal longitudinal and transverse composite stringer system, full length lifting strakes, underdeck wire conduits, and a molded non-skid deck with removal deck panels for below deck access. There is no wood in the vessel's construction.

### Tube Construction

The RIBCRAFT 5.85 features all tube accessories as outlined and is fully compliant. The RIBCRAFT 5.85 features a semi-active heavy duty multi chambered (five (5) chambers) 1670 dtx Hypalon tube. To insure the utmost in strength and reliability, all seams are triple bonded (overlapped with internal and external seam tapes), the tube is permanently bonded to the hull, and each chamber features pressure relief valves to prevent over inflation or blow outs. Additionally, every tube features a high profile rubstrake which is 1.25" high by 5" wide.

### Layout

The RIBCRAFT 5.85 features all accessories as outlined and is fully compliant. All of the required features are included as indicated in the enclosed itemized RIBCRAFT 5.85 Quote. Of critical importance, the proposed 5.85 features a center console with front bench seat, leaning post, T-top, and an antenna arch with integrated folding dive ladder.

### Engine

The proposed RIBCRAFT 5.85 features a single 115HP Mercury four stroke engine complete with digital controls, gauges, and propeller. The engine is equipped with hydraulic steering and the transom height is 25". The engine is directly mounted to the transom.

### Electrical/Electronics

The RIBCRAFT 5.85 features all electronics as outlined and is fully compliant. All wiring and electrical installations will meet or exceed ABYC standards. All of the required features are included as indicated in the enclosed itemized RIBCRAFT 5.85 Detailed Quote.

### Trailer

RIBCRAFT has proposed a dual axle heavy duty bunk trailer. Galv.?

## **WARRANTIES**

All warranty items are as specified in RIBCRAFT's standard commercial warranty. RIBCRAFT warrants the boat (hull and tube) for one year from date of purchase. Components and accessories not manufactured by RIBCRAFT receive the warranty provided by the original equipment manufacturer. The manufacturer of the Mercury engine offers a one year warranty for commercial users.

## **DELIVERY**

Currently, delivery for one new RIBCRAFT 5.85 as specified is estimated at approximately one hundred eighty (180) days from date of award of contract. RIBCRAFT will deliver the boat to Biddeford, ME upon completion at no charge.

## **SERVICE & SUPPORT**

As a manufacturer located in New England, RIBCRAFT is uniquely positioned to provide direct factory service and support. RIBCRAFT guarantees the continuing availability of Logistical Support (i.e. spares and other technical services) for a minimum of 10 years from time of delivery. As required, RIBCRAFT is happy to provide needed service support either directly through a RIBCRAFT factory service technician or a factory approved service center within the vessels' operation area. Given the proximity to Maine, RIBCRAFT's capability to provide service and support is paramount and allows you to work directly with the manufacturer, much like the Kennebunk Harbormaster, Portsmouth Fire, Boston Fire and Maine Marine Patrol have experienced.

RIBCRAFT will provide complete COTs Operation and Maintenance Manuals with complete third party manuals for all electronics and significant mechanical items (engine). As requested, RIBCRAFT will provide instruction and technical manuals.

## **PRICING**

The quoted price for the RIBCRAFT 5.85 and trailer as specified per the RFP is \$100,983.00. RIBCRAFT will deliver the completed boat, engine and trailer to Biddeford at no charge. A complete pricing detail is provided in the enclosed Detailed Quote.



PO Box 463, Marblehead, MA 01945  
 t. 781.639.9065 f. 781.639.9062  
 www.ribcraftusa.com

To: Biddeford Fire Department  
 Ken Thorpe  
 152 Alred Street  
 Biddeford, ME 04005

Phone:  
 Email: [kenneth.thorpe@biddefordmaine.org](mailto:kenneth.thorpe@biddefordmaine.org)

QUOTE		
Date	Delivery	Contact
9/22/25	TBD	Kelly M
Model	Hull #:	Rev.
5.85		
Ref:		

1	<b>2026 RIBCRAFT 5.85 PROFESSIONAL - Outboard Engine Configuration</b> <b>Base Boat</b> includes Center Console with Front Bench Seat and S/S Grab Handle, Access Hatches, Leaning Post, Cable Steering, Anchor Locker, Bow Eye, Bow Cleat, Two (2) Stern Tie Down Eyes, Six (6) Switch Electrical Panel, Battery, Battery Switch, Navigation Lights, Compass, Electric Bilge Pump, 46 Gallon Internal Fuel Tank, 1670dtx Hypalon Tube with Five (5) Chambers & Five (5) Pressure Relief Valves, Heavy Duty Rubstrake, Lifelines, Owners Manual, and Foot Pump	\$ 53,195.00	\$ 53,195.00
	<b>Console/ Seating</b>		
1	Full Size Windscreen Mounted to T-top	\$ 875.00	\$ 875.00
1	Leaning Post Backrest	\$ 470.00	\$ 470.00
1	Leaning Post Flip Up Footrest	\$ 420.00	\$ 420.00
	<b>Console/ Seating Sub Total: \$ 1,765.00</b>		
	<b>Accessories</b>		
1	T-top, Aluminum with hard top upgrade	\$ 10,915.00	\$ 10,915.00
1	T-top Electronics Box	\$ 1,450.00	\$ 1,450.00
1	Antenna Arch with Integrated Dive Ladder	\$ 6,960.00	\$ 6,960.00
	<b>Accessories Sub Total: \$ 19,325.00</b>		
	<b>Tube Accessories</b>		
1	Color Tube Upgrade - RED	\$ 1,575.00	\$ 1,575.00
1	Tube Grab Handles (pair)	\$ 195.00	\$ 195.00
1	Boarding Wear Patch (pair)	\$ 315.00	\$ 315.00
	<b>Tube Accessories Sub Total: \$ 2,085.00</b>		
	<b>Electrical/ Electronics</b>		
1	Additional Marine Battery with Isolator	\$ 365.00	\$ 365.00
1	LED Navigation Light Upgrade	\$ 260.00	\$ 260.00
1	LED Flood Lights, pair	\$ 775.00	\$ 775.00
	<b>Electrical/ Electronics Sub Total: \$ 1,400.00</b>		
	<b>Engines</b>		
1	Mercury 115HP Four Stroke Engine, complete rigging and installation	\$ 14,513.00	\$ 14,513.00
1	Hydraulic Steering (in-lieu) Single Engine Only	\$ 1,425.00	\$ 1,425.00
	<b>Engines Sub Total: \$ 15,938.00</b>		
	<b>Transport</b>		
1	Bunk Trailer with jack	\$ 6,545.00	\$ 6,545.00
1	Freight Prep: Load & Block	\$ 730.00	\$ 730.00
	<b>Transport Sub Total: \$ 7,275.00</b>		
	<b>Colors</b>		
	<b>Hull</b> Light Grey <b>Tube</b> Red <b>Console</b> Light Grey <b>Rubstrake</b> Black <b>Upholstery</b> Black <b>LL Patches</b> Black		
<b>NOTES: Items Listed Below Not Included in total quoted sales price</b>		<b>Sub Total</b>	\$ 100,983.00
		<b>Total Sales Price</b>	\$ 100,983.00
		<b>Deposit Required</b>	\$ 50,491.50
		<b>Balance to be Paid</b>	\$ 50,491.50

A deposit is required. Progress payments may be required. Delivery dates are not guaranteed.

The balance is due and payable upon completion and prior to the boat shipping. Prices for non-RIBCRAFT manufactured components are not guaranteed. Prices FOB: Origin

THE GENERAL CONDITIONS ON THE BACK AND ANY OTHERS, IF ANY, ARE HEREBY MADE A PART OF THIS QUOTE.

THIS DRAWING FILE (AND THE INFORMATION SHOWN THEREIN) IS CONFIDENTIAL AND PROPRIETARY AND SHALL NOT BE USED, DISCLOSED TO OTHERS, OR REPRODUCED BY ANY MEANS FOR ANY PURPOSE IN HARD COPY FORM OR IN MACHINE READABLE FILES, WITHOUT THE WRITTEN CONSENT OF RIBCRAFT USA LLC.

REVISIONS

REV	ZONE	DESCRIPTION	DATE

Specifications:

Length Overall..... 19'-4"  
 Internal Length..... 14'-9"  
 Beam (Tube Max)..... 8'-0"  
 Internal Beam..... 5'-1"  
 Tube Diameter..... 20"

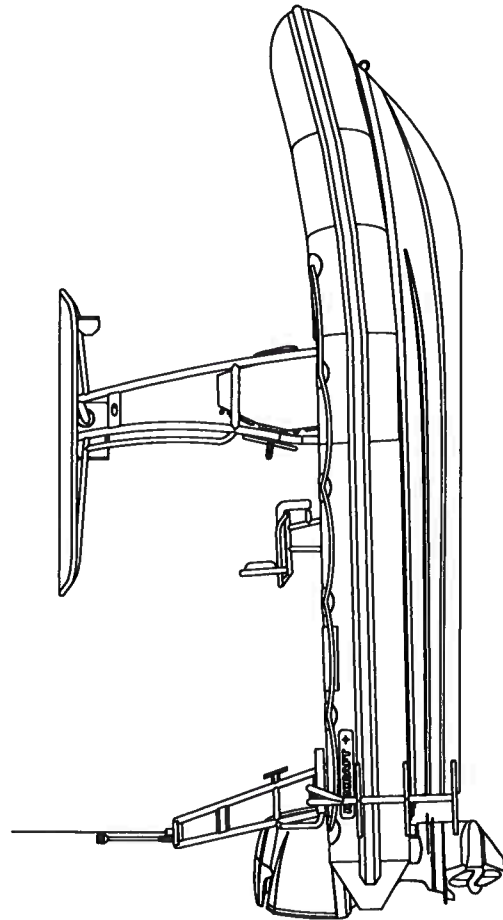
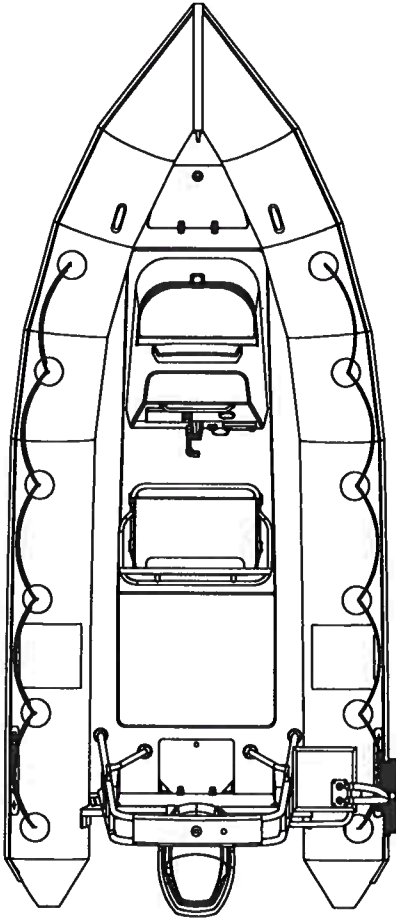

NOTE: LAYOUT IS PRELIMINARY AND SUBJECT TO CHANGE

**RIBCRAFT** ♦

RIBCRAFT 5.85 - Biddeford FD - General Arrangement

DWG NO. RC585-BFD-GA-01	REV ~
DRAWN ARL	DATE 18 SEPTEMBER 2025
SIZE A	SCALE None
SHEET 1 of 1	

5.85

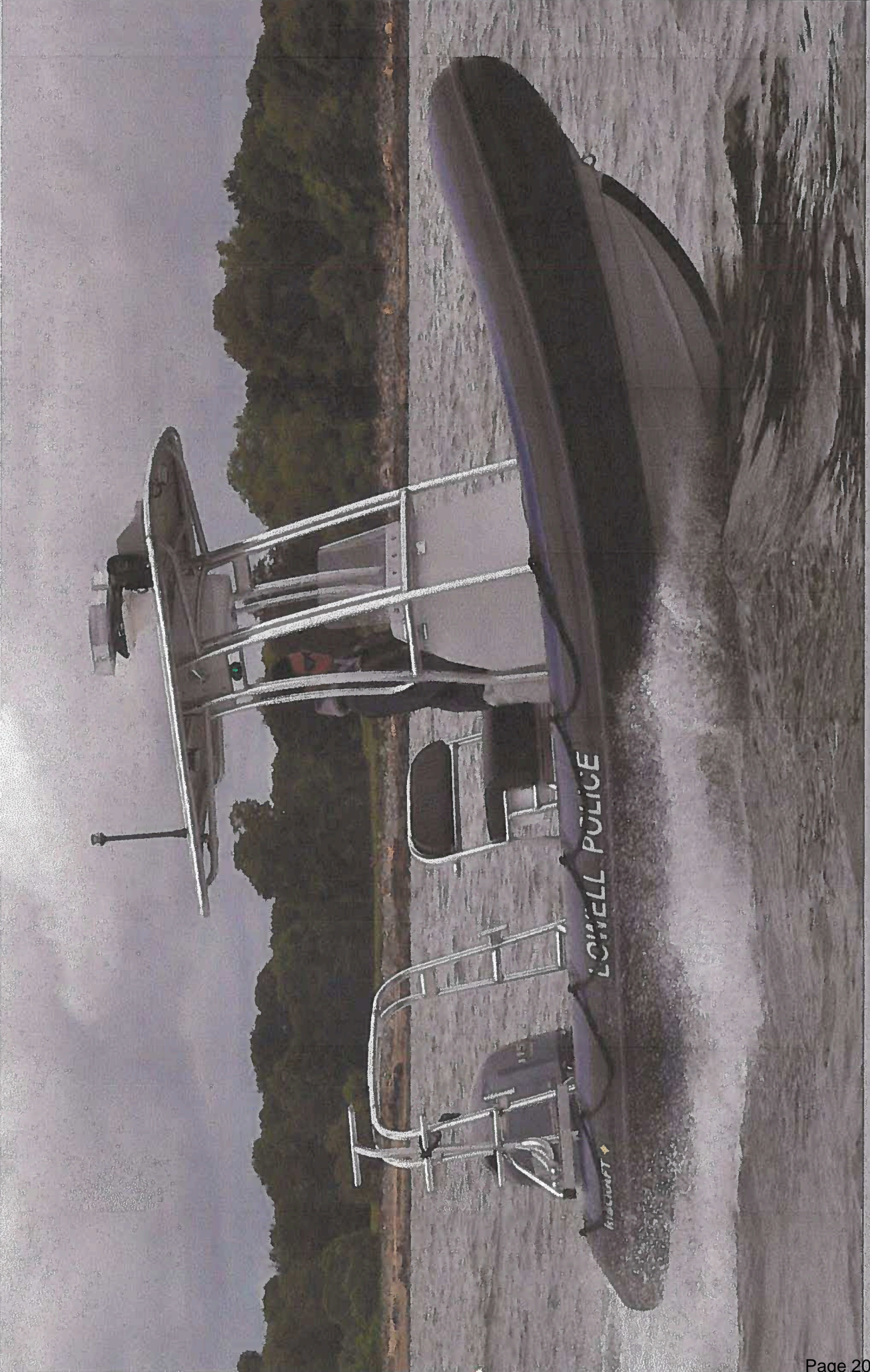

## Specifications and Details

Model	Image	Model	Image	Model	Image	Model	Image
<b>AF14 / AF16</b>		<b>4.8</b>		<b>5.7</b>		<b>5.85</b>	
LOA:	13'9" / 15'10"	LOA:	15'7"	LOA:	18'7"	LOA:	19'4"
Beam:	5'9" / 6'9"	Beam:	6'11"	Beam:	8'5"	Beam:	8'5"
Weight (w/out engine):	315 lbs / 390 lbs	Weight (w/out engine):	685 lbs	Weight (w/out engine):	1,890 lbs	Weight (w/out engine):	1,295 lbs
Dead rise aft:	N/A	Dead rise aft:	23°	Dead rise aft:	22°	Dead rise aft:	22°
Dead rise forward:	N/A	Dead rise forward:	43°	Dead rise forward:	43°	Dead rise forward:	43°
Tube diameter:	20" / 20"	Tube diameter:	18"	Tube diameter:	20"	Tube diameter:	20"
Internal length on deck:	10'2" / 11'6"	Internal length on deck:	11'10"	Internal length on deck:	13'10"	Internal length on deck:	14'9"
Internal beam on deck:	2'8" / 3'2"	Internal beam on deck:	4'1"	Internal beam on deck:	4'11"	Internal beam on deck:	5'1"
Draft (w/out engine):	7" / 7"	Draft (w/out engine):	12"	Draft (w/out engine):	14"	Draft (w/out engine):	14"
Maximum people:	8 / 10	Maximum people:	6	Maximum people:	10	Maximum people:	10
Max HP:	50 / 60	Max HP:	70	Max HP:	165	Max HP:	135
Fuel capacity:	6.6 gal*	Fuel capacity:	6.6 gal*	Fuel capacity:	33 gal	Fuel capacity:	46 gal
Tube:	1880 dtx Hypalon®	Tube:	1670 dtx Hypalon®	Tube:	1670 dtx Hypalon®	Tube:	1670 dtx Hypalon®
Chambers:	4+2 / 5+2	Chambers:	5	Chambers:	5	Chambers:	5
Pressure relief valves:	4 / 5	Pressure relief valves:	5	Pressure relief valves:	5	Pressure relief valves:	5
LOA:	21'5"	LOA:	21'5"	LOA:	21'5"	LOA:	21'5"
Beam:	8'5"	Beam:	8'5"	Beam:	8'5"	Beam:	8'5"
Weight (w/out engine):	1,365 lbs	Weight (w/out engine):	1,365 lbs	Weight (w/out engine):	1,365 lbs	Weight (w/out engine):	1,365 lbs
Dead rise aft:	25°	Dead rise aft:	25°	Dead rise aft:	25°	Dead rise aft:	25°
Dead rise forward:	44°	Dead rise forward:	44°	Dead rise forward:	44°	Dead rise forward:	44°
Tube diameter:	20"	Tube diameter:	20"	Tube diameter:	20"	Tube diameter:	20"
Internal length on deck:	16'4"	Internal length on deck:	16'4"	Internal length on deck:	16'4"	Internal length on deck:	16'4"
Internal beam on deck:	5'6"	Internal beam on deck:	5'6"	Internal beam on deck:	5'6"	Internal beam on deck:	5'6"
Draft (w/out engine):	16"	Draft (w/out engine):	16"	Draft (w/out engine):	16"	Draft (w/out engine):	16"
Maximum people:	12	Maximum people:	12	Maximum people:	12	Maximum people:	12
Max HP:	180	Max HP:	180	Max HP:	180	Max HP:	180
Fuel capacity:	60 gal	Fuel capacity:	60 gal	Fuel capacity:	60 gal	Fuel capacity:	60 gal
Tube:	1670 dtx Hypalon®	Tube:	1670 dtx Hypalon®	Tube:	1670 dtx Hypalon®	Tube:	1670 dtx Hypalon®
Chambers:	5	Chambers:	5	Chambers:	5	Chambers:	5
Pressure relief valves:	5	Pressure relief valves:	5	Pressure relief valves:	5	Pressure relief valves:	5

\*external tank

\*external tank, optional internal 16 gal tank available



RIBCRAFT USA, LLC  
88 Hoods Lane, PO Box 463  
Marblehead, MA 01945  
t. 781.639.9065 f. 781.639.9062  
toll free. 866 RIBS USA  
www.ribcraftusa.com

COPY

**PROPOSAL OPTION B**

September 22, 2025

City of Biddeford Fire Department  
152 Alfred Street  
Biddeford, ME 04005  
Attn: Assistant

**RE: RFP – Supply and Delivery of a Fire Department Emergency Response Boat**

On behalf of RIBCRAFT USA, LLC, I am pleased to provide you with the following proposal for one (1) RIBCRAFT 6.5 with all specified options and equipment in response to RFP – Supply and Delivery of a Fire Department Emergency Response Boat, dated August 20, 2025.

The RIBCRAFT 6.5 is built to the highest commercial grade specifications and standards resulting in remarkably solid, well performing, and safe rigid inflatable boat (RIB). As the manufacturer of the above stated boat, this boat meets the requirements put forth by the City of Biddeford Fire Department.

Please find enclosed the following documents:

- Completed & Signed Bid Documents
- Bidder Response Supplement
- Detailed RIBCRAFT Quote
- RIBCRAFT Brochure

With safety and reliability at the core of all RIBCRAFT designs, the RIBCRAFT 6.5 features a deep V hull, full-length spray rails, high bow sheer, and a heavy-duty multi chambered Hypalon tube. To insure the utmost in durability and strength all hulls are solid fiberglass with an internal composite stringer system.

For almost twenty-five years, safety and rescue professionals have come to expect the most in quality, dependability and service from RIBCRAFT and our line of professional grade rigid inflatable boats (RIBs). Constructed by skilled craftsmen in the United States (Massachusetts), every boat is built with the understanding that it will receive hard, offshore 24/7 commercial use.

Many thanks in advance for your time and consideration.

*Kelly Marie*

RIBCRAFT USA, LLC

**ATTACHMENT A:**

**REFERENCE FORM**

Bidder: RIBCRAFT USA, LLC

RFB Title: The Supply, and Delivery of a Fire Department Emergency Response Boat

**Bidder must provide references for:**

All current contracts under which the vendor's equipment has been operational for at least two years.

Reference: Spotsylvania Sherriff's Office Contact: Carter Wells  
Address: 9119 Dean Riding Lane Spotsylvania, VA 22553 Phone: 540-507-7195  
Fax: cwells@spotsylvania.va.us

Description and date(s) of supplies or services provided: RIBCRAFT built and delivered a RIBCRAFT 6.5 to the Spotsylvania Sherriff's Department in July of 2019. The boat had a smiliar layout with a center console, T-top, antenna arch with integrated dive ladder, and a 150HP outboard.

Reference: Portsmouth Fire Department Contact: John Goodwin  
Address: 170 Court Street Portsmouth, NH 03801 Phone: 603-944-7920  
Fax: jwgoodwin@cityofportsmouth.com

Description and date(s) of supplies or services provided: RIBCRAFT built and delivered a RIBCRAFT 7.8 to the Portsmouth Fire Department in April of 2019. RIBCRAFT worked with the Chief to understand their operational requirements and built a boat that meets all of their demands - a reliable and improved rescue boat that was also equipped with fire suppression capabilities.

Reference: Maine Marine Patrol Contact: Steve Ingram  
Address: 21 State House Station Augusta, ME 04333 Phone: 207-624-7338  
Fax: steve.ingram@maine.gov

Description and date(s) of supplies or services provided: RIBCRAFT has built and delivered numerous RIBCRAFT 4.8 boats to the Maine Marine Patrol. The RIBs are onboard MMP's larger patrol boats and a favorite among the officers and the most used boats in the fleet.

*attach additional sheets if necessary*

**ATTACHMENT B: BID FORM**

The undersigned BIDDER proposes and agrees, if the Bid is accepted to enter into an Agreement with the City, to complete all work as specified or indicated in the "REQUEST TO BID: for the supply, delivery of a FIRE DEPARTMENT EMERGENCY RESPONSE BOAT and TRAILER, exactly as outlined and detailed in this bid.

**Bid Price:** One hundred thirty two thousand nine hundred thirty seven dollars (\$ 132,937.00 )

BIDDER accepts all the terms and conditions of the Instructions to Bidders.

In submitting this Bid, BIDDER represents, as more fully set forth in the Agreement, that: BIDDER has examined copies of all the Contract Documents **and of the following Addenda:**

Date N/A  
Date

Number N/A  
Number

BIDDER shall submit an itemized list of costs including vessel accessories, attachments, trailer and delivery as outlined in this bid.

BIDDER agrees that Prevailing Wage Rates if applicable will be paid for the appropriate classification of work.

The undersigned certifies under penalties of perjury that this Bid is in all respects bona fide, fair and made without collusion or fraud with any other person. As used in this paragraph, the word "person" shall mean any natural person, joint venture, partnership, corporation or other business or legal entity.

Signed:  Print Name: Kelly Marie

Company: RIBCRAFT USA, LLC

Business Address: 88 Hoods Lane  
Marblehead, MA 01945

Email: kmarie@ribcraftusa.com

FAX:



RIBCRAFT USA, LLC  
88 Hoods Lane, PO Box 463  
Marblehead, MA 01945  
t. 781.639.9065 f. 781.639.9062  
toll free. 866 RIBS USA  
www.ribcraftusa.com

## **PROPOSAL OPTION B**

### **BIDDER RESPONSE SUPPLEMENT**

Proposal for RFP – Supply and Delivery of a Fire Department Emergency Response Boat

#### **CERTIFICATIONS / MANUFACTURERS EXPERIENCE:**

RIBCRAFT hereby certifies that the proposed 2026 21'5" RIBCRAFT 6.5 rigid inflatable boat and additional items related hereto are compliant with the technical specifications contained in the Invitation For Bid dated August 20, 2025 for RFP – Fire Department Emergency Response Boat. Such compliancy includes, but is not limited to, design, construction, performance, durability, and warranty except where indicated.

The proposed RIBCRAFT 6.5 Rigid Inflatable Boat is designed, built and tested in accordance with the American Boat & Yacht Council's quality technical practices and engineering standards for the design, construction and safety of small craft. The boat will be equipped and configured as specified in the bid package and shall meet all necessary requirements.

#### **EXPERIENCE / CREDENTIALS**

Headquartered in Marblehead, Massachusetts, RIBCRAFT designs and builds safe, durable, performance oriented rigid inflatable boats (RIBs) that fulfill the most demanding professional applications. For nearly 25 years, RIBCRAFT has built professional grade RIBs and inflatables in the United States for military applications, law enforcement agencies, safety professionals, and private industry. The RIBCRAFT model line ranges in size from 14 to 42 feet.

Since inception in 2001, RIBCRAFT USA, LLC has developed one of the strongest and most recognized brands in the rigid inflatable boat market. RIBCRAFT focuses on government and commercial users who comprise 85% of the company's revenues.

Every RIBCRAFT is built to customer-defined specifications following a detailed design process, including not only powering options and color schemes but also general arrangement, electrical packages, and myriad customer-specific equipment configurations. The RIBCRAFT team is comprised of marine professionals experienced in and passionate about designing and building RIBs that meet and exceed customer expectations and mission requirements.

Incorporating a conventional solid fiberglass hull with an inflatable tube for increased buoyancy, stability, and overall performance RIBCRAFT builds professional grade rigid

inflatable boats ranging in size from 14' to 42' that fulfill a variety of missions from patrol and rescue to interdiction and military operations. Every boat is built to industry recognized standards featuring commercial grade fiberglass hulls and heavy duty multi-chambered air tubes. Designed for professional applications, a RIBCRAFT RIB with a deep V hull and heavy duty tube provides unparalleled performance regardless of the sea conditions.

RIBCRAFT supplies the United States Navy with the standard 7 Meter shipboard RIB and the 11 Meter Expeditionary RIB. Additionally, RIBCRAFT supplies commercial grade boats to the US Air Force, US Fish & Wildlife, state and local law enforcement agencies, fire departments, and industry (profit & non-profit).

**REFERENCES:**

As requested, RIBCRAFT has built Fire and Rescue Boats for the following agencies in recent years:

Spotsylvania's Sherriff's Office  
9119 Dean Riding Lane  
Spotsylvania, VA 22553  
Carter Wells  
cwells@spotsylvania.va.us  
540-507-7195

Portsmouth Fire Department  
170 Court Street  
Portsmouth, NH 03801  
John Goodwin  
jwgoodwin@cityofportsmouth.com  
603-944-7920

Maine Marine Patrol  
21 State House Station  
Augusta, ME 04333  
Steve Ingram  
Steve.ingram@maine.gov  
207-624-7338

Louisa County Sherriff  
1 Woolfolk Ave, Suite 101  
Louisa, VA 23093  
Dustin Lowe  
dulowe@louisa.org  
540-967-0401

## **BOAT SPECIFICATIONS:**

Based on the invitation for bid and the estimated referenced value, RIBCRAFT hereby proposes the RIBCRAFT 6.5 as a rescue boat for the City of Biddeford. The RIBCRAFT 6.5 Rigid Inflatable Boat specifications are as indicated below and as illustrated in the attached RIBCRAFT 5.85 Specification Marketing Sheet.

LOA:	21'5"
Beam:	8'5"
Internal Length:	16'4"
Internal Beam:	5'6"
Weight:	1,400 – 1,800 lbs (without engine)

The proposed 2026 RIBCRAFT 6.5 features a commercial grade fiberglass deep V hull with a heavy duty 1670 dtx red Hypalon tube with five air chambers each with pressure relief valves, a pair of boarding wear patches and a pair of tube grab handles. The boat is configured with a center console with front bench seat, full size windscreen, leaning post with backrest, footrest and storage, a t-top with aluminum hard top, antenna arch with integrated dive ladder, LED navigation and flood lights, a 150HP Mercury four stroke outboard engine, a bunk trailer and all other features and options as specified in the Scope of Services.

Please see the enclosed Detailed Quote and Drawing for the quoted configuration which outlines all features and options included.

The RIBCRAFT 6.5 meets the requirements and specifications for the boat and engine as outlined in the RFP August 20, 2025.

### Length/Measurements

The RIBCRAFT 6.5 at 21'5" as proposed is fully compliant with the specifications as noted above and in the Scope of Services.

### Hull Construction

The RIBCRAFT 6.5 as proposed is fully compliant with the features outlined. Featuring a heavy duty commercial grade solid fiberglass (FRP) hull, the 6.5 also includes an internal longitudinal and transverse composite stringer system, full length lifting strakes, underdeck wire conduits, and a molded non-skid deck with removal deck panels for below deck access. There is no wood in the vessel's construction.

### Tube Construction

The RIBCRAFT 6.5 features all tube accessories as outlined and is fully compliant. The RIBCRAFT 6.5 features a semi-active heavy duty multi chambered (five (5) chambers) 1670 dtx Hypalon tube. To insure the utmost in strength and reliability, all seams are triple bonded (overlapped with internal and external seam tapes), the tube is permanently bonded to the hull, and each chamber features pressure relief valves to prevent over inflation or blow outs. Additionally, every tube features a high profile rubstrake which is 1.25" high by 5" wide.

### Layout

The RIBCRAFT 6.5 features all accessories as outlined and is fully compliant. All of the required features are included as indicated in the enclosed itemized RIBCRAFT 6.5 Quote. Of critical importance, the proposed 6.5 features a center console with front bench seat, leaning post, T-top, and an antenna arch with integrated folding dive ladder.

### Engine

The proposed RIBCRAFT 6.5 features a single 150HP Mercury four stroke engine complete with digital controls, gauges, and propeller. The engine is equipped with hydraulic steering and the transom height is 25". The engine is directly mounted to the transom.

### Electrical/Electronics

The RIBCRAFT 6.5 features all electronics as outlined and is fully compliant. All wiring and electrical installations will meet or exceed ABYC standards. All of the required features are included as indicated in the enclosed itemized RIBCRAFT 6.5 Detailed Quote.

### Trailer

RIBCRAFT has proposed a dual axle heavy duty bunk trailer.

## **WARRANTIES**

All warranty items are as specified in RIBCRAFT's standard commercial warranty. RIBCRAFT warrants the boat (hull and tube) for one year from date of purchase. Components and accessories not manufactured by RIBCRAFT receive the warranty provided by the original equipment manufacturer. The manufacturer of the Mercury engine offers a one year warranty for commercial users.

## **DELIVERY**

Currently, delivery for one new RIBCRAFT 6.5 as specified is estimated at approximately one hundred eighty (180) days from date of award of contract. RIBCRAFT will deliver the boat to Biddeford, ME upon completion at no charge.

## **SERVICE & SUPPORT**

As a manufacturer located in New England, RIBCRAFT is uniquely positioned to provide direct factory service and support. RIBCRAFT guarantees the continuing availability of Logistical Support (i.e. spares and other technical services) for a minimum of 10 years from time of delivery. As required, RIBCRAFT is happy to provide needed service support either directly through a RIBCRAFT factory service technician or a factory approved service center within the vessels' operation area. Given the proximity to Maine, RIBCRAFT's capability to provide service and support is paramount and allows you to work directly with the manufacturer, much like the Kennebunk Harbormaster, Portsmouth Fire, Pittsfield Fire and Maine Marine Patrol have experienced.

RIBCRAFT will provide complete COTs Operation and Maintenance Manuals with complete third party manuals for all electronics and significant mechanical items (engine). As requested, RIBCRAFT will provide instruction and technical manuals.

## **PRICING**

The quoted price for the RIBCRAFT 6.5 and trailer as specified per the RFP is \$132,937.00. RIBCRAFT will deliver the completed boat, engine and trailer to Biddeford at no charge. A complete pricing detail is provided in the enclosed Detailed Quote.



PO Box 463, Marblehead, MA 01945  
 t. 781.639.9065 f. 781.639.9062  
 www.ribcraftusa.com

To: Biddeford Fire Department  
 Ken Thorpe  
 152 Alred Street  
 Biddeford, ME 04005

Phone:  
 Email: [kenneth.thorpe@biddefordmaine.org](mailto:kenneth.thorpe@biddefordmaine.org)

QUOTE		
Date	Delivery	Contact
9/22/25	TBD	Kelly M
Model	Hull #:	Rev.
6.5		
Ref:		

1	<b>2026 RIBCRAFT 6.5 PROFESSIONAL - Outboard Engine Configuration</b> Base Boat includes Center Console with Front Bench Seat and SS Grab Handle, Two (2) Access Hatches, Leaning Post, Hydraulic Steering, Anchor Locker, Bow Eye, Bow Cleat, Two (2) Stern Tie Down Eyes, Eight (8) Switch Electrical Panel, Battery, Battery Switch, Navigation Lights, Compass, Electric Bilge Pump, 60 Gallon Fuel Tank, 1670 dtx Hypalon Tube with Five (5) Chambers & Five (5) Pressure Relief Valves, Heavy Duty Rubstrake, Lifelines, Owner's Manual, Foot Pump	\$ 80,915.00	\$ 80,915.00
	<b>Console/Seating</b>		
1	Full Size Windscreen Mounted to T-top	\$ 875.00	\$ 875.00
1	Leaning Post Backrest	\$ 480.00	\$ 480.00
1	Leaning Post Flip Up Footrest	\$ 425.00	\$ 425.00
	<b>Console/ Seating Sub Total: \$ 1,780.00</b>		
	<b>Accessories</b>		
1	T-top, Aluminum with hard top upgrade	\$ 11,040.00	\$ 11,040.00
1	T-top Electronics Box	\$ 1,630.00	\$ 1,630.00
1	Antenna Arch with Integrated Dive Ladder	\$ 7,850.00	\$ 7,850.00
	<b>Accessories Sub Total: \$ 20,520.00</b>		
	<b>Tube Accessories</b>		
1	Color Tube Upgrade - RED	\$ 1,630.00	\$ 1,630.00
1	Tube Grab Handles (pair)	\$ 195.00	\$ 195.00
1	Boarding Wear Patch (pair)	\$ 315.00	\$ 315.00
	<b>Tube Accessories Sub Total: \$ 2,140.00</b>		
	<b>Electrical/ Electronics</b>		
1	Additional Marine Battery with Isolator	\$ 365.00	\$ 365.00
1	LED Navigation Light Upgrade	\$ 260.00	\$ 260.00
1	LED Flood Lights, pair	\$ 775.00	\$ 775.00
	<b>Electrical/ Electronics Sub Total: \$ 1,400.00</b>		
	<b>Engines</b>		
1	Mercury 150HP Four Stroke Engine, complete rigging and installation with hydraulic steering	\$ 18,162.00	\$ 18,162.00
	<b>Engines Sub Total: \$ 18,162.00</b>		
	<b>Transport</b>		
1	Bunk Trailer with jack	\$ 7,245.00	\$ 7,245.00
1	Freight Prep: Load & Block	\$ 775.00	\$ 775.00
	<b>Transport Sub Total: \$ 8,020.00</b>		
	<b>Colors</b>		
	<b>Hull</b> Light Grey <b>Tube</b> Red		
	<b>Console</b> Light Grey <b>Rubstrake</b> Black		
	<b>Upholstery</b> Black <b>LL Patches</b> Black		
<b>NOTES: Options listed below not included in total quoted price</b>		<b>Sub Total</b>	\$ 132,937.00
		<b>Total Sales Price</b>	\$ 132,937.00
		Deposit Required	\$ 66,468.50
		Balance to be Paid	\$ 66,468.50

A deposit is required. Progress payments may be required. Delivery dates are not guaranteed.

The balance is due and payable upon completion and prior to the boat shipping. Prices for non-RIBCRAFT manufactured components are not guaranteed. Prices FOB: Origin

THE GENERAL CONDITIONS ON THE BACK AND ANY OTHERS, IF ANY, ARE HEREBY MADE A PART OF THIS QUOTE.

THIS DRAWING FILE (AND THE INFORMATION SHOWN THEREIN) IS CONFIDENTIAL AND PROPRIETARY AND SHALL NOT BE USED, DISCLOSED TO OTHERS, OR REPRODUCED BY ANY MEANS FOR ANY PURPOSE IN HARD COPY FORM OR IN MACHINE READABLE FILES, WITHOUT THE WRITTEN CONSENT OF RIBCRAFT USA LLC.

REVISIONS

REV	ZONE	DESCRIPTION	DATE

Specifications:

Length Overall..... 21'-5"  
 Internal Length..... 16'-4"  
 Beam (Tube Max)..... 8'-5"  
 Internal Beam..... 5'-6"  
 Tube Diameter..... 20"

NOTE: LAYOUT IS PRELIMINARY AND SUBJECT TO CHANGE

**RIBCRAFT** ♦

RIBCRAFT 6.5 - Biddeford FD - General Arrangement

DWG NO. RC65-BFD-GA-01	REV ~
DRAWN ARL	DATE 18 SEPTEMBER 2025
SIZE A	SCALE None
SHEET 1 of 1	

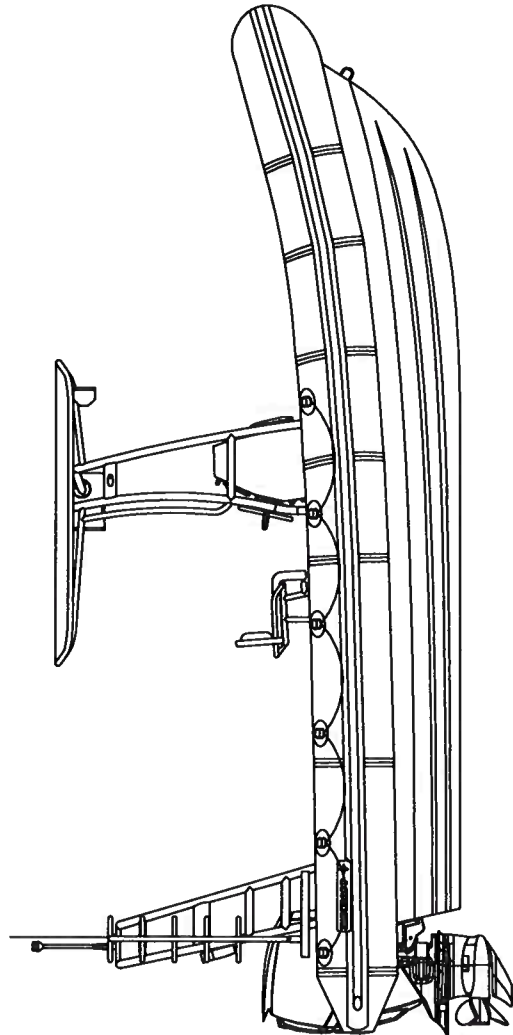
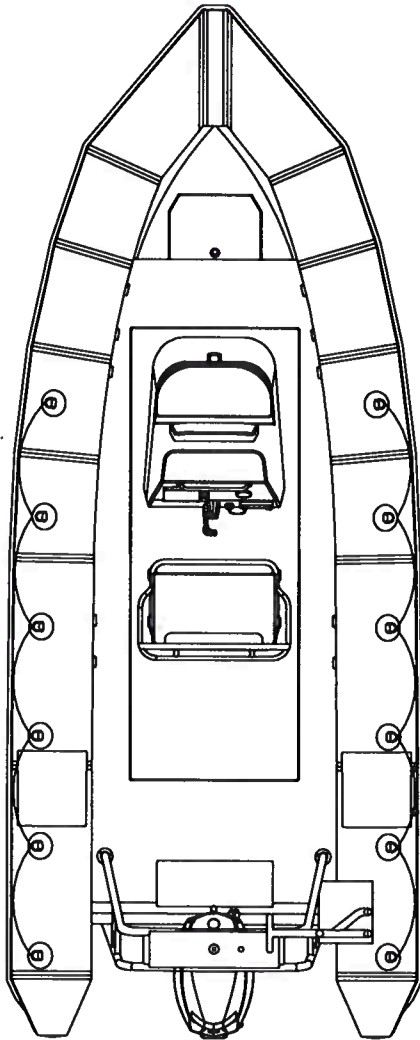

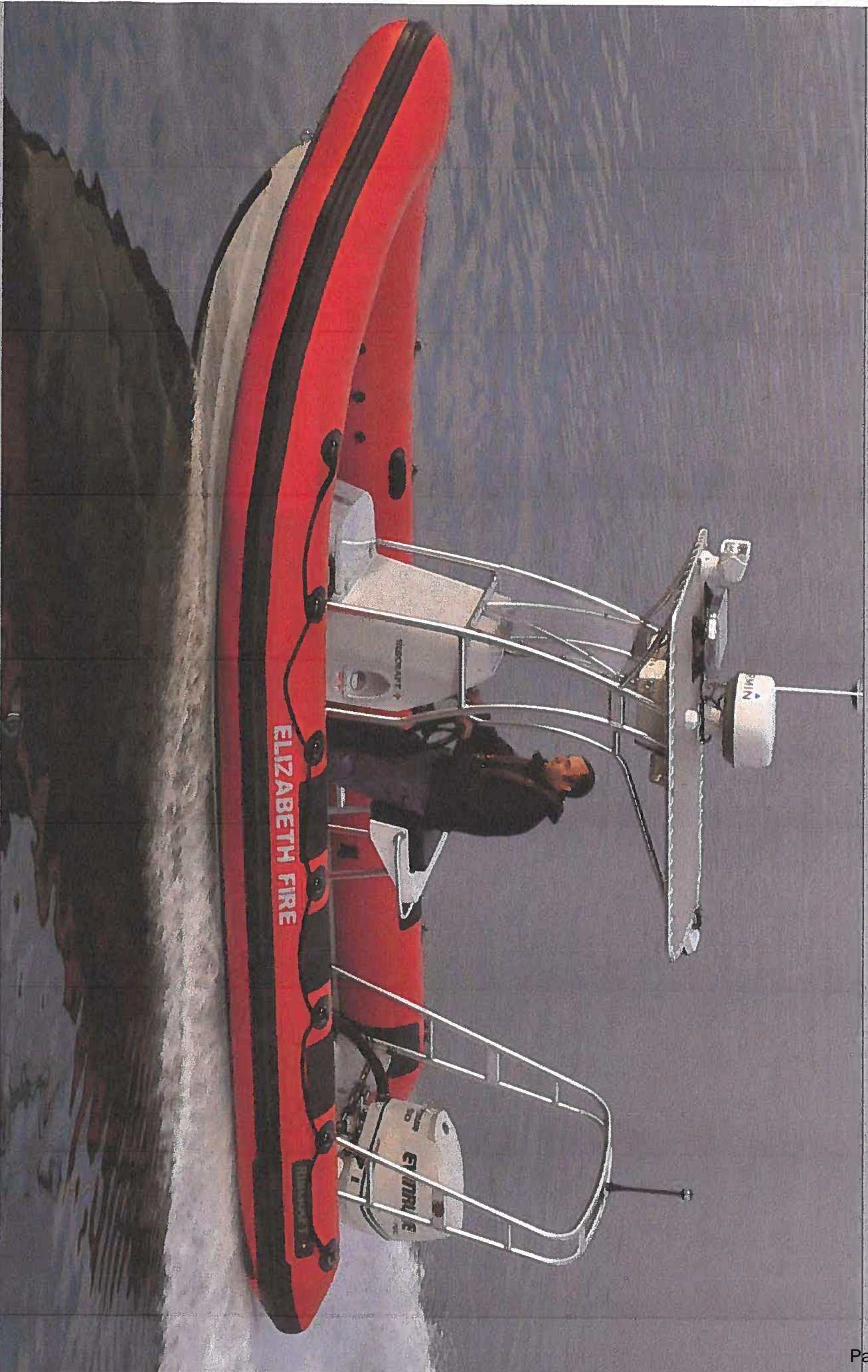

**Specifications and Details**

Model	Image	LOA:	Beam:	Weight (w/out engine):	Dead rise aft:	Dead rise forward:	Tube diameter:	Internal length on deck:	Internal beam on deck:	Draft (w/out engine):	Maximum people:	Max HP:	Fuel capacity:	Tube:	Chambers:	Pressure relief valves:
AF14 / AF16		139" / 15'10"	5'9" / 6'9"	315 lbs / 390 lbs	N/A	N/A	20" / 20"	10'2" / 11'6"	2'8" / 3'2"	7" / 7"	8 / 10	50 / 60	6.6 gal*	1880 dtx Hypalon®	4+2 / 5+2	4 / 5
4.8		15'7"	6'11"	685 lbs	23°	43°	18"	11'10"	4'1"	12"	6	70	6.6 gal*	1670 dtx Hypalon®	5	5
5.7		18'7"	8'5"	1,890 lbs	22°	43°	20"	13'10"	4'11"	14"	10	165	33 gal	1670 dtx Hypalon®	5	5
5.85		19'4"	8'	1,295 lbs	22°	43°	20"	14'9"	5'1"	14"	10	135	46 gal	1670 dtx Hypalon®	5	5
6.5		21'5"	8'5"	1,365 lbs	25°	44°	20"	16'4"	5'6"	16"	12	180	60 gal	1670 dtx Hypalon®	5	5

\*external tank  
 \*external tank, optional internal 16 gal tank available





September 19, 2025

City of Biddeford Fire Department  
152 Alfred Street  
Biddeford, Maine, 04005

Subject: Zodiac North America, Inc. Response to Request for Proposal  
**The Supply, and Delivery of a Fire Department Emergency Response Boat**

Encl: 1) Cover Page  
2) Attachment A  
3) Attachment B  
4) ZNA INC. quote sheet, drawing package, technical data package, and warranty statement

Dear City of Biddeford Fire Department

Zodiac of North America Inc. (ZNA) is pleased to provide the enclosed technical and pricing proposal in response to Request for **The Supply, and Delivery of a Fire Department Emergency Response Boat** Zodiac of North America will be offering our Zodiac MilPro branded SRA 650 craft platform as per town specification – This platform is used mostly by Federal, State, and Local Fire Rescue Units around the world – Zodiac of North America is proud to have this platform built in our United States facility located in Stevensville Maryland

Thank you for the opportunity to offer our Zodiac Milpro products in response to this solicitation.

Respectfully,

Justin R. Antolini  
Commercial Sales Director  
Zodiac of North America Inc.  
540 Thompson Creek Road  
Stevensville, Maryland 21666  
Tax ID Number: 52-0906929  
Gage Code: 60042  
Duns Number: 059174847  
GSA Contract Number: GS07F0298V

**ATTACHMENT A:**

**REFERENCE FORM**

Bidder: Zodiac Of North America Inc.

RFB Title: City of Biddeford Fire Department Invitation for Bids for  
The Supply, and Delivery of a Fire Department Emergency Response Boat

**Bidder must provide references for:**

All current contracts under which the vendor's equipment has been operational for at least two years.

Reference: St. Leonard Vol. Fire Dept Contact: Chief Brent Lankford  
Address: 200 Calvert Beach Rd, St Leonard, MD 20685 Phone: 443-532-5549  
Fax: \_\_\_\_\_

Description and date(s) of supplies or services provided: \_\_\_\_\_  
Zodiac MilPro SRR 650 / 6.5 meter fiberglass fire rescue platform  
Delieverd January 2023

Reference: Sunapee Fire Department Contact: John Galloway  
Address: 9 Sargent Rd, Sunapee, NH 03782 Phone: (603) 763-5770  
Fax: \_\_\_\_\_

Description and date(s) of supplies or services provided: \_\_\_\_\_  
Zoidac MilPro SRA 650 / 6.5 Meter Aluminum Fire Rescue Boat with portable fire suppression system  
Delievered March 2023

Reference: Longboat Key Police Department Contact: Frank Rubino  
Address: 5460 Gulf of Mexico Drive, Longboat Key FL 34228 Phone: 941-316-1201  
Fax: 941-373-7727

Description and date(s) of supplies or services provided: \_\_\_\_\_  
Zoidac MilPro SRR 530 / 5.3 Meter Fiberglass Police Patrol / Water Rescue Boat  
Delievered September of 2022

*attach additional sheets if necessary*

**ATTACHMENT B: BID FORM**

The undersigned BIDDER proposes and agrees, if the Bid is accepted to enter into an Agreement with the City, to complete all work as specified or indicated in the "REQUEST TO BID: for the supply, delivery of a FIRE DEPARTMENT EMERGENCY RESPONSE BOAT and TRAILER, exactly as outlined and detailed in this bid.

**Bid Price:** One Hundred Twenty Eight Thousand and Five Hundred dollars (\$ 128,500.00 )

BIDDER accepts all the terms and conditions of the Instructions to Bidders.

In submitting this Bid, BIDDER represents, as more fully set forth in the Agreement, that: BIDDER has examined copies of all the Contract Documents **and of the following Addenda:**

Date	Number

BIDDER shall submit an itemized list of costs including vessel accessories, attachments, trailer and delivery as outlined in this bid.

BIDDER agrees that Prevailing Wage Rates if applicable will be paid for the appropriate classification of work.

The undersigned certifies under penalties of perjury that this Bid is in all respects bona fide, fair and made without collusion or fraud with any other person. As used in this paragraph, the word "person" shall mean any natural person, joint venture, partnership, corporation or other business or legal entity.

Signed:  Print Name: Justin R. Antolini

Company: Zodiac Of North America Inc.

Business Address: 540 Thompson Creek Road  
Stevensville, Maryland 21666

Email: justin.antolini@zodiacmilpro.com

FAX: 410-643-4491

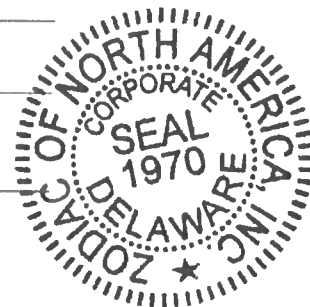

**Subject: Qt2509-0556- SRR 650- Biddeford FD**

**From:**                      **Name:** Justin Antolini  
                                    **Phone:** 410-443-6439  
                                    **Email:** Justin.Antolini@ZodiacMilPro.com

**To:**                            **Name:** City of Biddeford ME  
                                    **Phone:**  
                                    **Email:**

**Company:**                      Biddeford Fire Dept.

**Date:**                         9/11/2025

Zodiac of North America is pleased to present the following quote for the SRR 650

Accompanying the quote are general assembly renderings of your vessel, showing basic configuration.

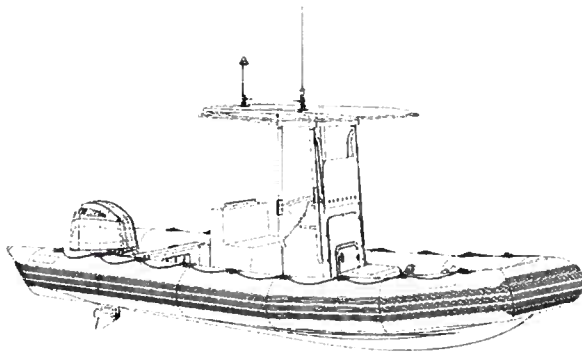

**1. PRICE & CONFIGURATION**

SRR 650		Qty	EXT
<b>RHIB</b>			
	Zodiac Milpro SRR 650, Red Tube	1	
	- Auto-Inflation System	1	
	- Gorilla Handles on Collar	2	
	- Step Tread/ Boarding wear patch's	8	
<b>Structural Equipment</b>			
	MED Console, Fiberglass	1	
	T-top for the MED Console w/ ALU Hard Top	1	
	- Custom Large Windshield	1	
	Yeti Cooler Front Seat.	1	
<b>Nav/Com Package</b>			
	NavLight Package, LED	1	
	Garmin VHF 115 Marine Radio	1	
	Garmin GPSMAP 943xsv MFD	1	
	Garmin Transducer GT51M-TM	1	
	Ritchie Compass Black F-82	1	
	Rigid Flood Light Package	1	
<b>Propulsion Package "Rigged Boat"</b>			
	Yamaha F150XCA Outboard Engine 25" Shaft Length	1	
	- PreRig, Single 150 HP Yamaha 25" Shaft Mechanical Shift and Throttle	1	
	Yamaha Spec Prop	1	
<b>Standard Systems</b>			
	Steering System, Hydraulic	1	
	Fuel System, SRR 650, USG, EPA	1	
	- Label / Warning Package	1	
	Bilge Package	1	
<b>Electrical System</b>			
	2 Engine 3 Battery Electrical System	1	
	6 Switch Panel	1	

SRR 650		
<b>Misc.</b>		
Anchor Package, Fortress	1	
Armstrong Dive Ladder	1	
Ez Loader Aluminum Trailer dual axel	1	
Logos and Lettering TBD Customer Spec	1	
<b>Sell Price, SRR 650 Delivered to City of Biddeford Fire Department:</b>		<b>\$ 128,500.00</b>

OPTIONS AND EXTRAS		
<b>REMOVE OUTBOARD ENGINE "NON RIGGED PACKAGE"</b>		
REMOVE: Yamaha F150XCA Outboard Engine 25" Shaft Length	1	-\$15,000.00
<b>SALES PRICE "NON RIGGED PACKAGE" NO OUTBOARD ENGINE:</b>		<b>\$ 113,500.00</b>
<b>ADD TOWING PACKING</b>		
ADD: SRR 650 Towing Package. Rope Guard/ Engine Guard, Bow Post, and Aft Tow Post	1	+\$9,000.00
<b>SALES PRICE ADD TOWING PACKAGE:</b>		<b>\$ 137,500.00</b>
<b>ADD EMERGENCY LIGHT PACKAGE</b>		
ADD: WHELEN Lightbar and Siren/ Haller.	1	+\$3,780.00
<b>SALES PRICE ADD EMERGENCY LIGHT PACKAGE:</b>		<b>\$ 132,280.00</b>

**2. PRICE & CONFIGURATION**

Tax Resale/Exemption Certificate. Sales and Resale/Exemption Certificate must be provided to ZNA at time of order.

Tariffs and trade regulations can change frequently. We reserve the right to modify our pricing to account for any changes in tariffs or government regulations that may affect the price of our products. Customers will be informed of any such changes with justification, upon ZNA price impact determination. Remedy will be mutually agreed before shipping.

**Shipping Terms:**

Incoterms 2020, FOB DESTINATION Biddeford FD

**ZNA Proposed Payment Schedule:**

25% At Time of Order

50% At Completion of Hull Production

25% At Time of Successful Sea Trial

**Delivery:**

Estimate Date of Readiness to be Shipped: **9-10 Months from Date of PO**

**Validity:**

Prices shown on this quote sheet are valid for **90 Days** from Date of Quote.

**General Selling Conditions:**

1. All custom orders are not returnable.
2. Payments made by credit cards may be subject to a 3% processing fee.
3. Packaging, freight, and shipping fees are estimates. The actual amount will be provided at time of invoicing plus a 15% administration fee.
4. Late payments are subject to a 2% per month late fee.

Best Regards,

Justin Antolini  
Commercial Sales Director  
Zodiac of North America

Alec Pupshis  
Project Manager  
Zodiac of North America

<b>Acceptance of Order:</b>	
<i>I agree to the terms and prices of this proposition</i>	
NAME:	_____
COMPANY:	_____
SIGNATURE	

# SRR 650

## SEA RIB RESPONDER

The Sea RIB Responders are designed for patrol and intervention duties. The range extends from 4.2 meters to 11 meters. All sizes feature a removable slide-on collar with a traditional round section that provides great stability in rough seas. The SRR is a shore based platform that can maintain a significant cruise speed in seas with short wavelength or large offshore swell. Fuel tanks are integrated below deck for sizes above 5m.

A variety of standard accessories featuring open, semi-closed or fully enclosed cabins is available to customize the configuration to the mission requirements. The SRR boats have been in operation worldwide for decades in Navies, Border Guard, Fire-Fighters and other authorities units from desartic to polar conditions.

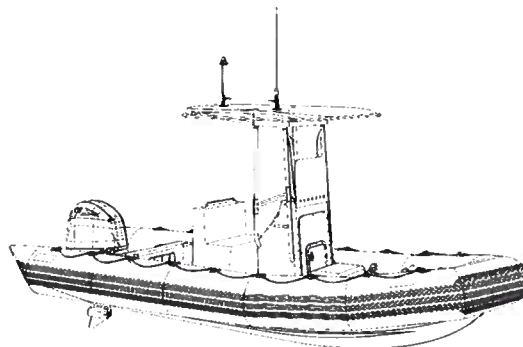

**Dimensions - LENGTH**

Length inflated with rope guard	21ft 11in
Length inflated without rope guard and engine tilted down	21ft 4in
Length inflated without rope guard and engine tilted up	23ft 4in
Length - Bare hull without tube	17ft 7in
Internal gross length - from inner collar vertical at bow to transom	16ft 3in
Internal net length - usable workdeck length	11ft 0in

**Dimensions - WIDTH**

Width inflated	8ft 6in
Width deflated	5ft 11in
Width - Bare hull	5ft 9in
Internal net width - usable deck width	4ft 6in

**Dimensions - HEIGHT**

Height - from keel to aft frame or mast aerals*	12ft 6in
---	----------

**Dimensions - DRAFT**

Draft - from waterline to keel - with max. payload*	Cat B: 1ft 10in Cat C: 2ft 2in
---	-----------------------------------

**Dimensions - SURFACE**

Internal gross surface - within the top-of-collar periphery	55.33 sq ft
Internal net surface - Usable deck without coaming & boxes	40.04 sq ft

**Dimensions - TUBE**

Tube Diameter	1ft 11.5in
Tube volume (no dive door version)	121.1 cubic feet
Number of tube compartment	5
Valve set up	4 Intercommunication valves
Tube installation	slid-on Removable
DURATANE Fabric type	1670 dtx
Tube shape	ROUND Shape
Tube color available	Grey, Black, Orange, Blue, Green
Optional tube features	.Rapid access door .Treadmaster anti-slip patches .Bow protective net

## DESIGN CRITERIA

Available certification	(2013/53/EU) Design Category B and C
Acceleration criteria for hull structure & rule	Hull structure compliant to Bureau Veritas NR600 classification for an acceleration criteria of 3g.
Operational Profile - Class Design speed @SS0	40 kt

## WEIGHT & CAPACITY

Minimum displacement* - MMOC	3,337 lbs
Maximum displacement* - MLDC	Cat B: 5,732lbs Cat C: 7,496lbs
Usable payload' (MLDC - MMOC)*	Cat B: 2,395lbs Cat C: 4,158lbs
Number of persons*	Cat B: 5 pax Cat C: 15 pax

## HULL DESIGN

Hull Material	Infused Glassfiber Polyester
Hull shape	Deep V
Hull deadrise angle - at transom	24°
Hull deadrise angle - amidship	24°
Deck anti-slip	Molded antiskid surfacing
Deck equipment fixation	on Inserts
Hull drainage	.Self-draining deck through transom bailer .Manual plus electric bilge pump

## TOWING & MOORING

Standard Strong fittings	1 Bow towing eye 2 Towing transom U-bolts
Optional Strong fittings	.Bow towing post .Aft towing post .Special equipment post

## LIFTING

Standard Lifting fittings	4 Lift points
---------------------------	---------------

## DECK ARRANGEMENT

Standard Deck Fittings	.Bow box .Aft technical locker
Optional- Available Consoles	.Single man GRP console .Medium GRP console .Double GRP console
Optional - Available Seatings	.Bolster .Fixed jockey .Mitigated Milpro AIR jockey
Optional - Aerial installation	.Roll bar
Other Optional Deck fittings	.Storage box .Storage pouch .Dive bottle support .Liferaft with support .Self-righting system

## ELECTRICAL SYSTEM

Electrical system	Customized battery package with dual purposes 12 VDC AGM marine battery with bi-polar battery switches and automatic charging relays if multiple batteries.
-------------------	---

## PROPULSION

Engine configuration	SINGLE or TWIN Outboard
Minimum recommended power	100hp
Maximum power installation	150 hp   551 lbs 2x 100 hp   2x 419lbskg
Maximum allowed engine weight	551lbs   2x419lbs
Shaft length - Outboard engine	X-25"   L-20"

## FUEL SYSTEM

Tank configuration	Single rotomolded fuel tank integrated below deck
Fuel capacity	1x 240 L
Fuel system	Fuel gauge, filter & shut of valve

## PERFORMANCES

Typical speed capability at lightship with max. engine power*	up to 36 knots
Typical range capability at lightship with max. engine power*	up to 250 nm

\*Items marked with \* may vary with final configuration

# ZODIAC MILPRO

## SRR 650 BIDDEFORD FD

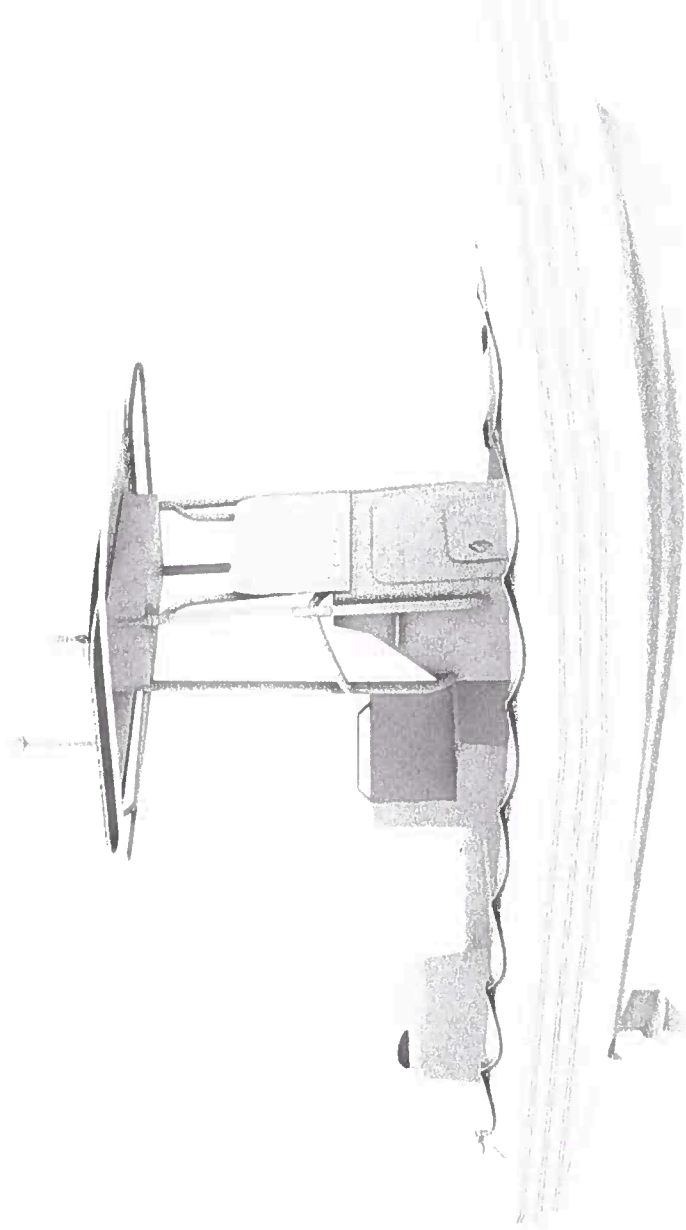

# ZODIAC MILPRO

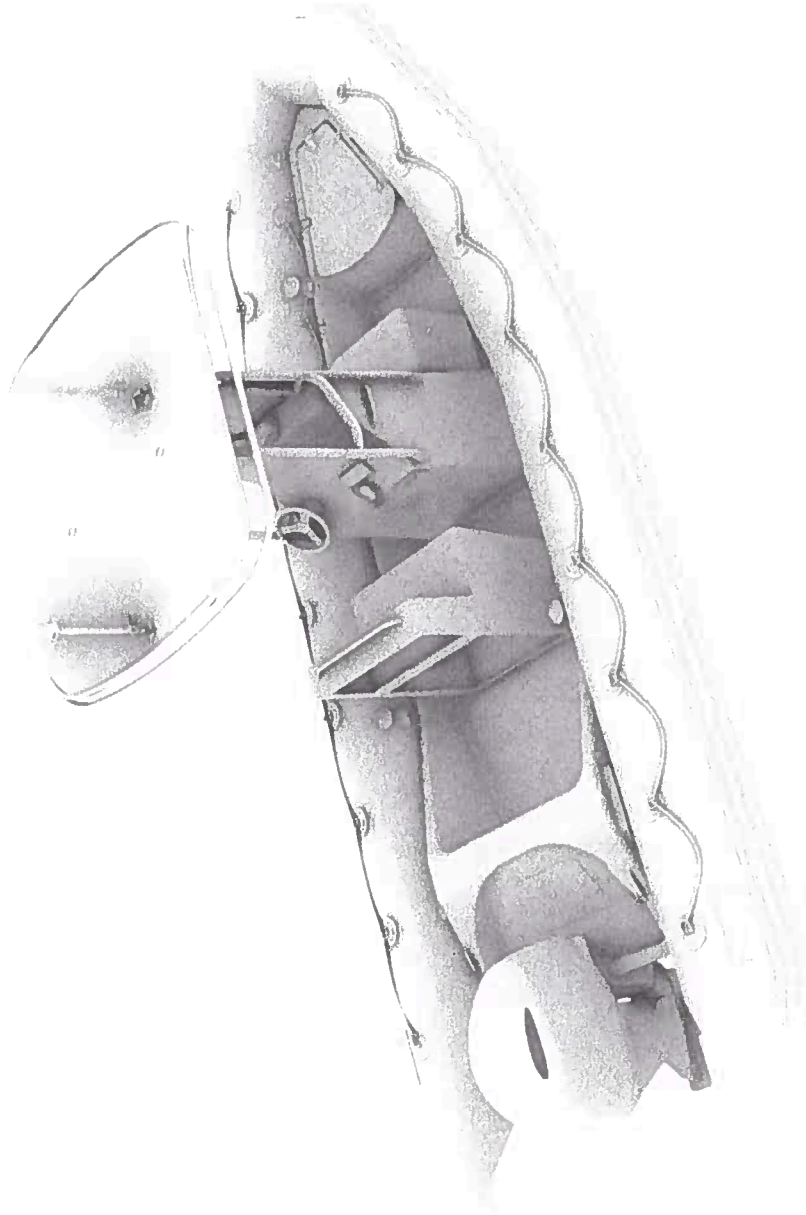

# ZODIAC MILPRO

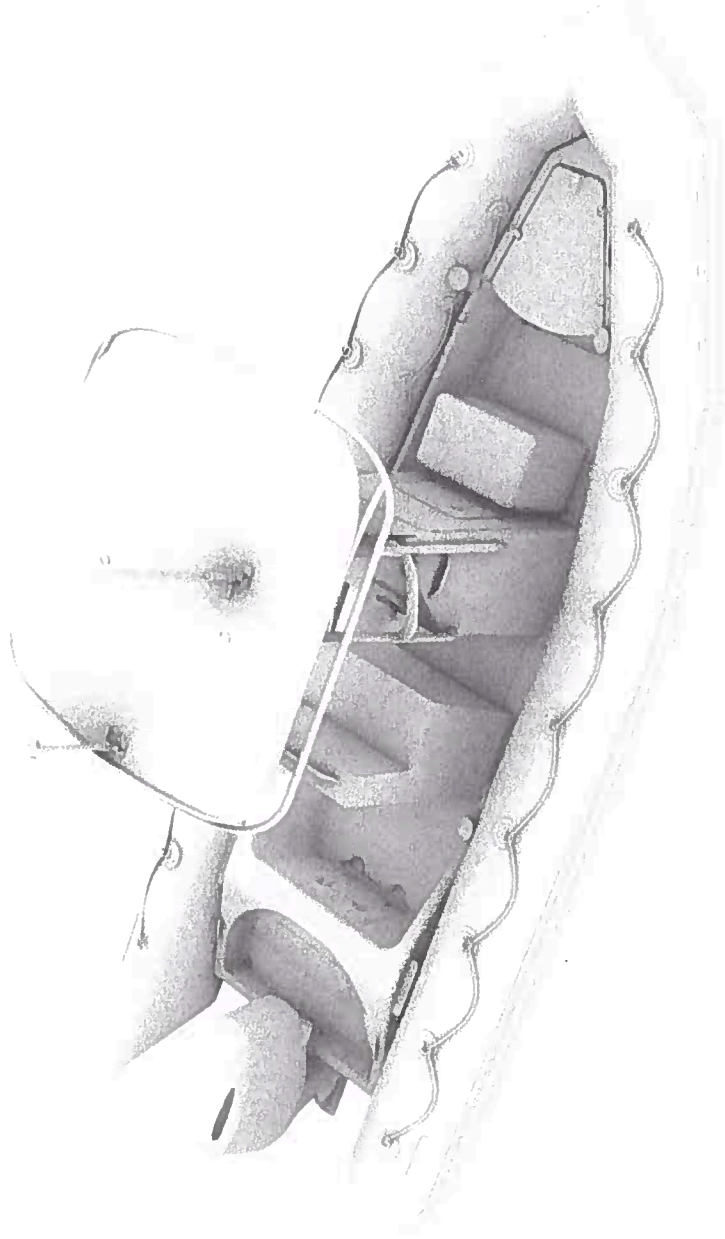

# ZODIAC MILPRO

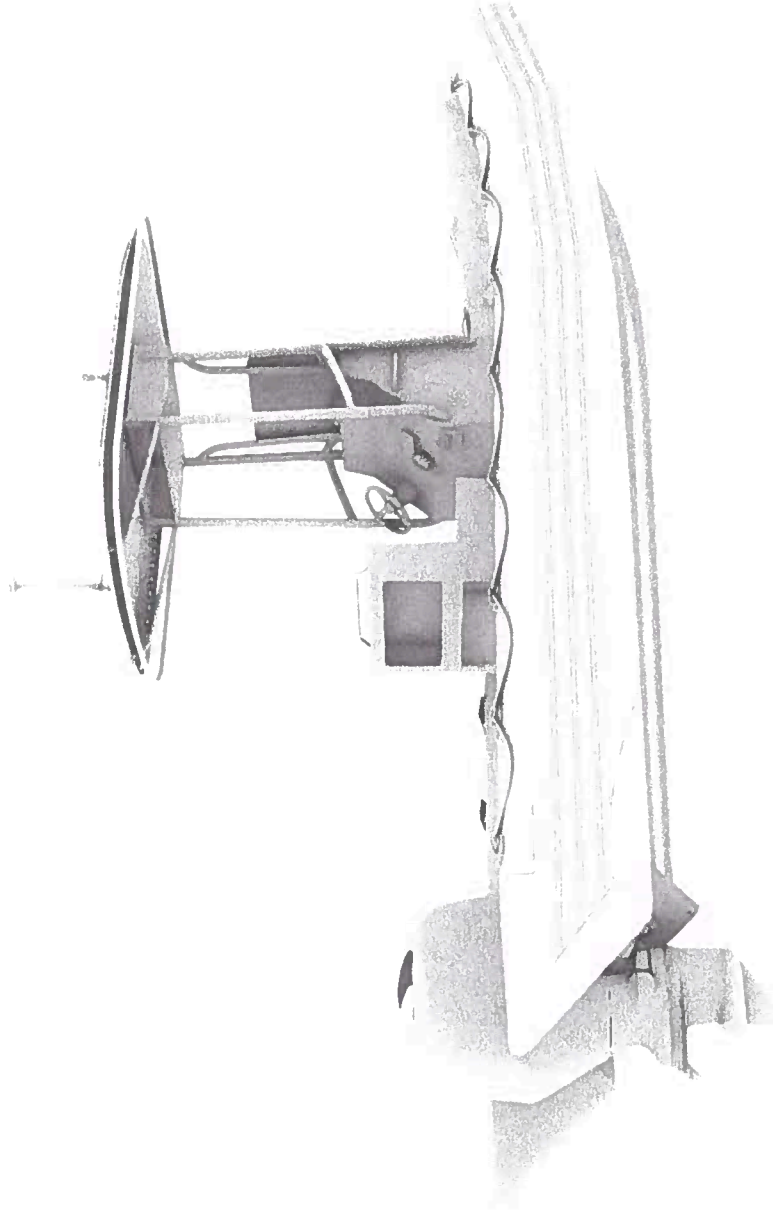

# ZODIAC MILPRO

## SRRR 650 OPTIONAL TOWING PACKAGE

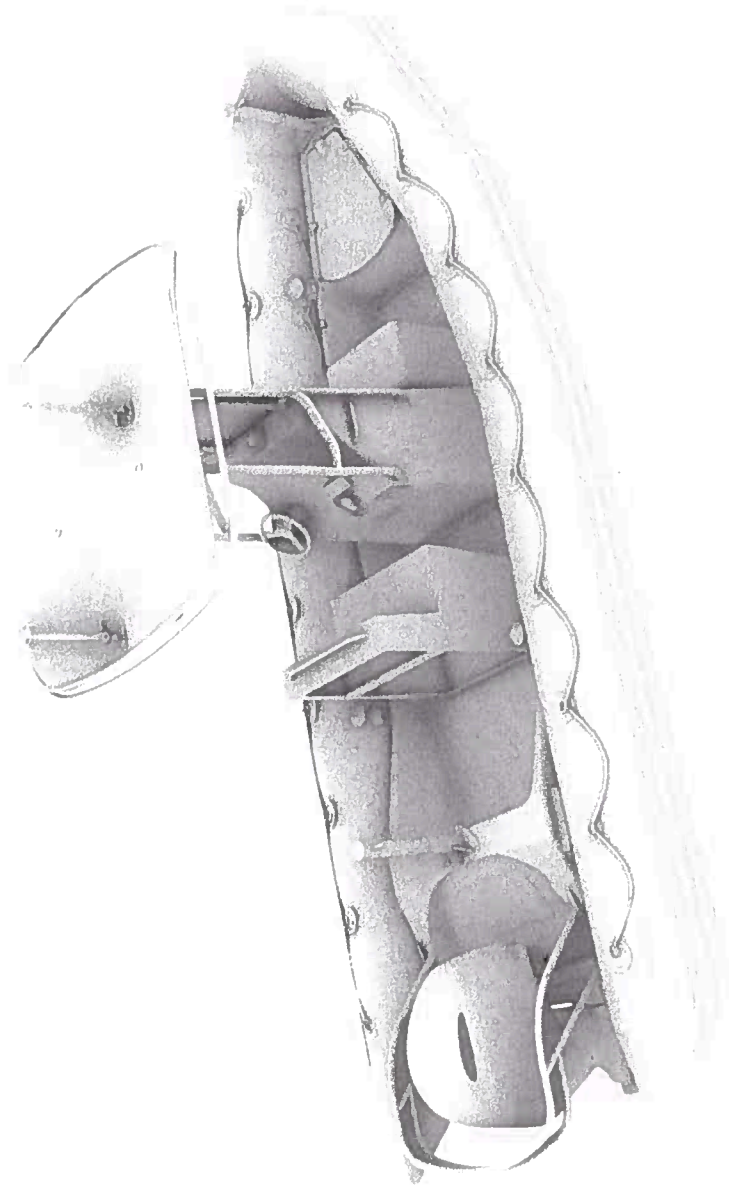

# ZODIAC MILPRO

## SRR 650 OPTIONAL OUTBOARD ENGINE “NON RIGGED PACKAGE”

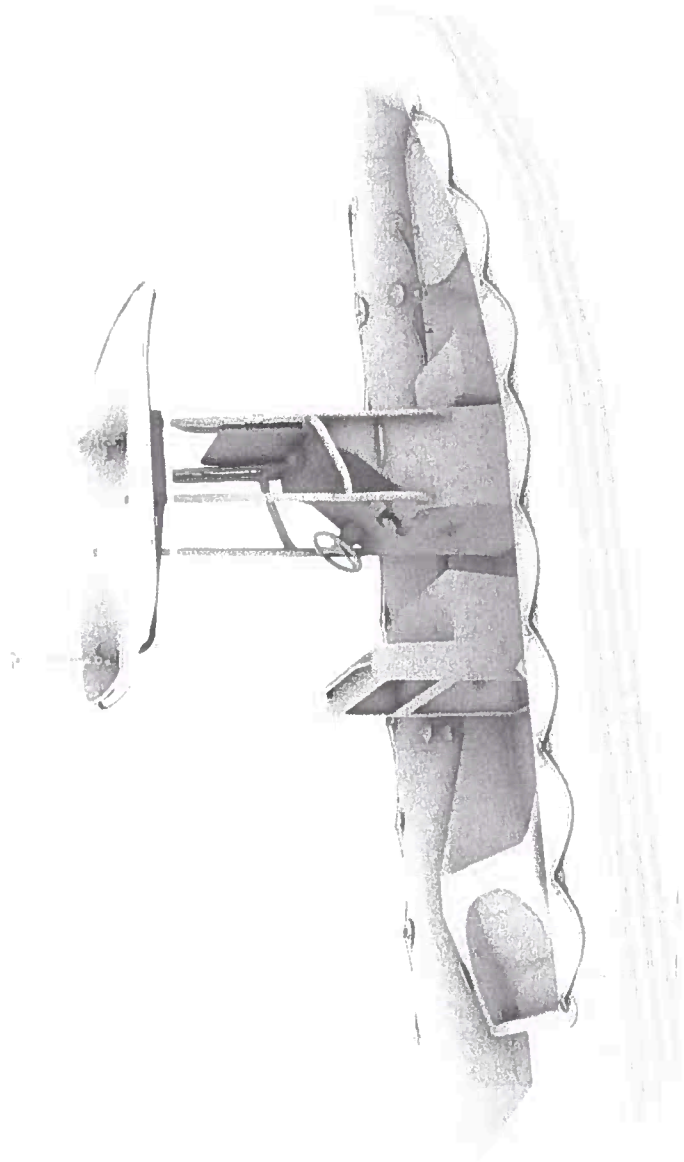

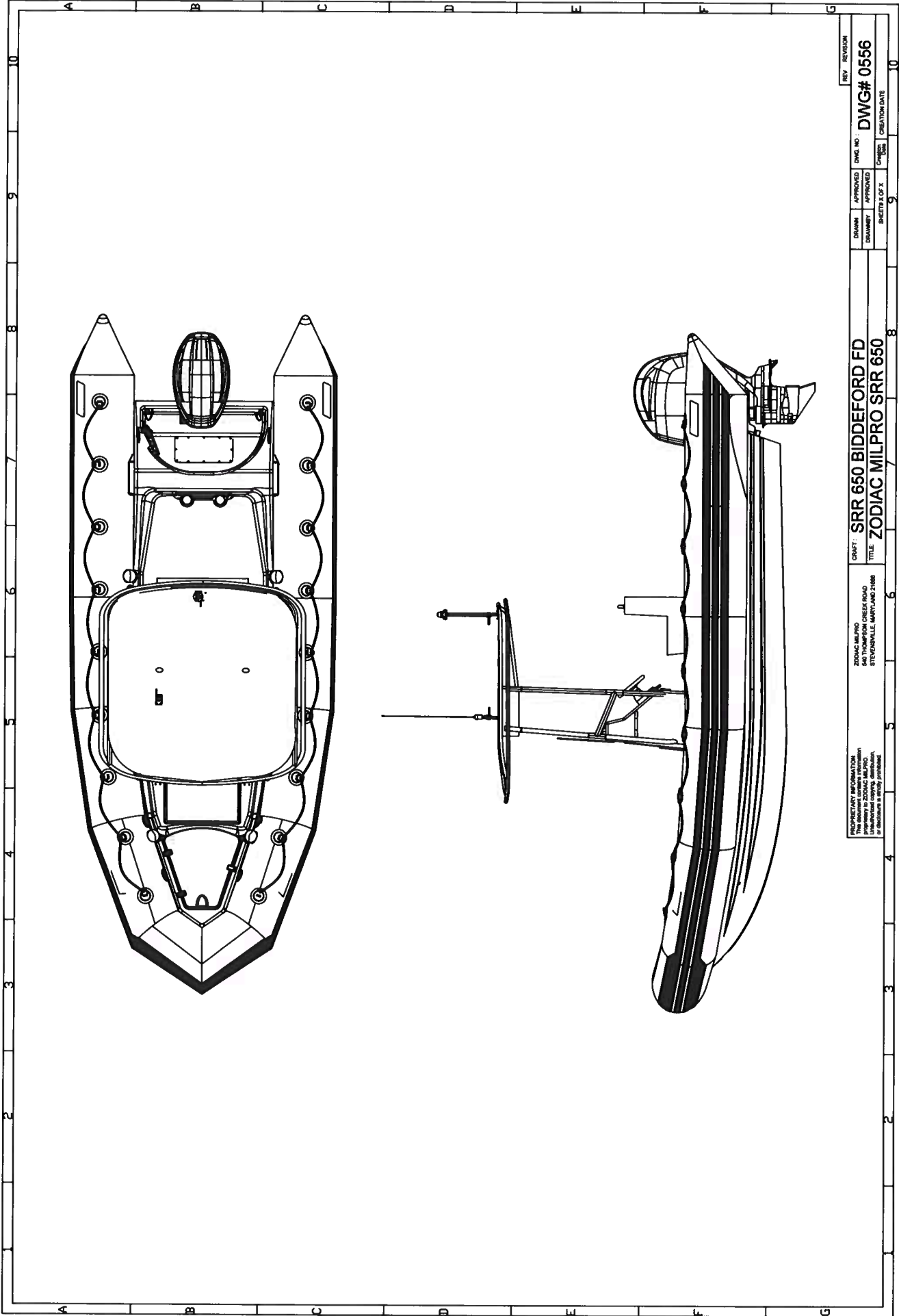

**PROPRIETARY INFORMATION**  
 This document contains information  
 that is the property of Zodiac  
 Inflatables and is not to be  
 reproduced, copied, distributed,  
 or otherwise made public without  
 the express written permission  
 of Zodiac Inflatables.

**DESIGNER:** MILPRO  
**MANUFACTURER:** ZODIAC  
**ADDRESS:** 1000 CRENSHAW  
 STEUBENVILLE, OHIO 45681

**MODEL:** SRR 650 BIDDEFORD FD  
**TITLE:** ZODIAC MILPRO SRR 650

DATE	APPROVED	DWG. NO.	REV. / REVISION
01/15/08	[Signature]	DWC# 0556	
SHEETS 8 OF 8		CREATION DATE	



## Zodiac of North America, Inc. 1 Year Warranty Certificate

The warranty on this ZODIAC MilPro inflatable boat or rigid hull inflatable boat is limited to the original purchaser who registers their product with Zodiac of North America (ZNA), 540 Thompson Creek Road, Stevensville, MD 21666 within 30 days of first placing the boat into service by returning the completed warranty card to ZNA. This Warranty is transferable, provided the original purchase was registered, and provided written notification of the transfer of the boat is received by Zodiac within 30 days of transfer. Note: Boats built by Zodiac Hurricane Technologies (ZHT) are subject to the terms the ZHT warranty and are not covered by this Zodiac MilPro warranty.

The warranty period inception:

- If the product is sold by a dealer the warranty period begins on the date of sale to the end customer.
- If the boat is sold to the end customer by ZNA, the warranty period begins on the date the boat is placed in service, or one year from the date it is shipped from ZNA, whichever is earlier.
- If the boat is sold to the end customer through a federal contract (e.g. GSA), the warranty period begins on the date the boat is placed in service, or one year from the date it is shipped from ZNA, whichever is earlier.

Zodiac milpro warrants the fabric of the buoyancy tubes, air floors, keels, the transom, transom attachments, and fiberglass hull of the boat to be free from defects in materials and workmanship for a period of 1 (one) year from date of purchase or Zodiac will repair or replace said product (at its sole discretion) at no charge for labor and materials (excluding shipping costs). Zodiac retains the right to substitute comparable product. The air holding seams are warranted to meet the Zodiac manometer standards for a period of 1 (one) year. Zodiac parts, attachments and accessories, unless covered individually by a separate warranty, are warranted to be free from defects in material and structure for a period of 1 (one) year or Zodiac will repair or replace said product (at its sole discretion) at no charge for labor and materials (excluding shipping costs). Zodiac retains the right to substitute comparable product. This warranty will be void if the Hull Identification Number (H IN) plate attached to the transom is changed, defaced or detached in any way.

After inspection of the condition of the boat by an authorized service center, determination of any warranty action will be made by Zodiac of North America.

#### EXCLUSIONS FROM THIS WARRANTY

- a) All inboard and outboard engines, transmissions, jet drives, generators, air conditioning systems, batteries, appliances, antifouling bottom paint and any other components and accessories not manufactured by Zodiac. (See owner's packet received at sale for separate warranty details, if any, on these products.)
- b) Misuse, abuse or negligence, including without limitation, improper docking, beaching or towing, collision, punctures, tearing, ripping, abrasion, theft, fire, and over/under inflation of air chambers.
- c) Damage received as a result of insertion/extraction, by helicopter, airplane parachute, submarine and the like.
- d) Damages or corrosion from abnormal environmental conditions, including but not limited to, corrosive water environment, airborne fallout, tree sap, chemical spills, acid rain, hail, wind storm, lightning, etc.
- e) Damages from contact with hydrocarbon products, fuel, gasoline, diesel, JP4/5/8, etc.
- f) Damages or corrosion due to lack of maintenance, or premature wearing resulting from improper assembly, over/under inflation, etc.
- g) Damages resulting from improper storage.
- h) The use of outboard engine in excess of that specified on the capacity plate.

- i) Competition usage is not warranted.
- j) Damage received through Acts of God, including but not limited to, abnormal water, wind or weather conditions, etc., are not warranted.
- k) Damages resulting from improper trailering, lifting, cradling, or improper use of davits.
- l) Alteration or tampering, including but not limited to, transom modification, installation of an engine with incorrect shaft length, etc.
- m) Normal deterioration, wear, discoloration, dulling, crazing, osmotic blistering and aging of fabrics, metals, woods, plastic or fiberglass gel coat (including spider cracks).
- n) Cost of normal maintenance and cleaning.
- o) Costs resulting from loss of use, including but not limited to transportation or freight to service centers, rigging/de-rigging.
- p) Consequential or incidental damages.
- q) Moisture damage to wooden parts, wooden laminates or composite assemblies resulting from failure to maintain the protective coating of these parts (varnish, paint, caulking, etc.)
- r) Use of strong detergents or silicone based products (ArmorAll or like agents) placed on the buoyancy tubes will void this warranty.

#### PROCEDURES

To receive service under this warranty you must take your boat or claimed defective part with proof of purchase (bill of sale) to an authorized service center for inspection during normal working hours. For the location of the nearest service center you may contact us by telephone (410) 643-4141 or our web page [www.zodiacmilpro.com](http://www.zodiacmilpro.com) or by writing to: Zodiac of North America, 540 Thompson Creek Road, Stevensville, MD 21666. All warranty actions are handled by the service center. To be eligible for warranty determination, you must contact your nearest center within 30 days of occurrence of the claimed defect.

#### LIMITATION OF LIABILITY AND OTHER IMPORTANT INFORMATION

This warranty is exclusive and in lieu of all other expressed warranties. ALL IMPLIED WARRANTIES, INCLUDING BUT NOT LIMITED TO THE IMPLIED WARRANTIES OF MERCHANTABILITY AND FITNESS FOR A PARTICULAR PURPOSE, ARE SPECIFICALLY DISCLAIMED. If any implied warranties are found to exist, such implied shall not extend beyond the duration of the express warranties provided herein. It is expressly agreed that no warranties can be made by the boat dealer/retailer, except those stated above.

Zodiac Milpro's sole obligation, and your exclusive remedy under this warranty, is limited to repair or replacement in accordance with this warranty.

Zodiac Milpro shall not be liable for any consequential, incidental or contingent damages whatsoever. Some states and provinces do not allow (a) limitation on how long a warranty lasts, or (b) the exclusion or limitation of incidental or consequential damages; so these limitations or exclusions may not apply to you. This warranty gives you specific legal rights, which vary from province to province or state to state.

Zodiac Milpro reserves the right to make changes in the design and material of its inflatable boats without incurring any obligation to incorporate such changes in units already completed or in the hands of dealers or consumers. The entire obligation of Zodiac Milpro regarding the sale of its inflatable is stated within this written warranty, except as otherwise provided by law. The distributor, Zodiac of North America, 540 Thompson Creek Road, Stevensville, MD 21666, make these warranties to you.

Zodiac Milpro does not authorize its dealer or any other person to assume for it any other warranty or liability in connection with its products.

This warranty is effective as to all boats sold from September 1, 2006 and supersedes all previous warranties.

1/4/2021

Zodiac of North America, Inc.

540 Thompson Creek Road, Stevensville, MD 21666

Phone: (410) 643-4141 Fax: (410) 604-0121

**FY26 CIP - Capital Projects / Operations Committee Recommendation No. 1 - Summary**

Allocation Category	Preliminary Proposal	Committee Recommendation No. 1 (06/11/25)	Balance to be Allocated
Committee Discretion	\$ 20,000		\$ 20,000
Vehicles <sup>1</sup>	\$ 422,300	\$ 300,700	\$ 121,600
Paving	\$ 900,000	\$ 500,000	\$ 400,000
Project	\$ 806,410	\$ 35,000	\$ 771,410
Fund 001	\$ 2,148,710.00	\$ 835,700	\$ 1,313,010

<sup>1</sup>The Committee authorized the purchase of all recommended vehicles totaling \$422,300, with the following exceptions: Unit 213-Detective and Marine Unit 202-Rescue, be funded from Fund 268 and Fund 202, respectively. This leaves a balance of \$121,600.

Fund 268 -	\$41,600 for detective vehicle
Fund 202 -	\$80,000 for marine Unit 202 (rescue boat)
Fund 601 -	\$22,389 Lease pmt for 610 wastewater pump truck
Fund 601 -	\$25,000 Lease pmt for camera truck (new)

**FY2026 Capital Improvement Projects Recommendation No. 1 (A) - Vehicle Recommendations, General Fund 001**

Description	Year	Request	Cash or DP			Lease	Notes	Capital Projects / Operations Committee Recommendation		
			Cash	or DP				Cash or DP	Lease	Notes
213 Car for Detective	2010	\$ 41,600	\$ 41,600							Approved, charge to Asset Forfeiture Account
015 Front End Loader	2009	\$ 191,017	\$ 75,000	\$ 1,202	10-year lease		\$ 75,000	\$ 1,202		
698 Skid Steer Loader	2003	\$ 35,700	\$ 35,700				\$ 35,700			
Mid Excavator	New	\$ 170,000	\$ 75,000	\$ 985	10-year lease		\$ 75,000	\$ 985		
698 Mower (to zero steer)	2003	\$ 45,000	\$ 45,000				\$ 45,000			
61 F-600 (Recycling vehicle)	2011	\$ 70,000	\$ 70,000		Alternatively, repurpose retireing ambulance		\$ 70,000			
Marine Unit 202 (rescue boat)	2010	\$ 80,000	\$ 80,000							Approved, charge to Mooring Fund
328 Fire Truck Pumper	2005	\$ 650,000								Approved, authorized to place order
<b>General Fund</b>		<b>\$ 1,283,317</b>	<b>\$ 422,300</b>	<b>\$ 2,187</b>			<b>\$ 300,700</b>	<b>\$ 2,187</b>		
CIP Vehicle Allocation (Recommended)			\$ 422,300				\$ 422,300			
<b>Balance</b>			<b>\$ -</b>				<b>\$ 121,600</b>			<b>Balance to be allocated in Recommendation No. 2</b>
<b>Description</b>	<b>Year</b>	<b>Request</b>	<b>Cash</b>	<b>Lease</b>						
610 Waste Water Pump Truck	2010	\$ 180,000	\$	22,386	Lease payment = \$1,865/mo	Capital Allocation	\$ 22,386	Lease payment = \$1,865/mo		
Camera Truck (new)		\$ 400,000	\$	25,000	Lease payment = \$4,166/mo	35102-60603	\$ 25,000	Lease payment = \$4,166/mo		
<b>Wastewater Fund 601</b>		<b>\$ 580,000</b>	<b>\$</b>	<b>47,386</b>			<b>\$ 47,386</b>			
CIP Vehicle Allocation (Recommended)			\$	47,386			\$ 47,386			

**FY2026 Capital Improvement Projects Recommendation No. 2 - Vehicle Recommendations, General Fund 001**

Description	Year	Request	Cash or DP			Lease	Notes	Capital Projects / Operations Committee Recommendation		
			Cash	or DP				Cash or DP	Lease	Notes
004 Fire Dept Service Pick-up	2012	\$ 64,000	\$ 64,000				\$ 64,000.00			
Dropped off list in 2025										
<b>General Fund</b>		<b>\$ 64,000</b>	<b>\$ 64,000</b>	<b>\$ -</b>			<b>\$ 64,000</b>	<b>\$ -</b>		
CIP Vehicle Allocation (Recommended)			\$ 64,000				\$ 121,600			
<b>Balance</b>			<b>\$ -</b>				<b>\$ 57,600</b>			<b>Balance to be applied to CIP Project Allocation</b>

**CIP BUDGET**  
**BIDDEFORD CAPITAL IMPROVEMENT PROGRAM**  
**FY26 Viewing Sheet**  
**PROJECT DESCRIPTION FORM**

DEPARTMENT:	Fire Department
CIP NAME:	Marine Unit 202 Replacement

CIP NUMBER: (DEPT-YR-#)	BFD-FY26-005
DEPARTMENT NUMBER	005
PROJECT PRIORITY	1

ESTIMATED TOTAL COST	\$80,000
ESTIMATED COST FY2026	\$80,000
ESTIMATED COST FY2027-2030	\$

CITY SHARE FY2026	\$80,000
CITY SHARE FY2027-2030	\$

1. DESCRIPTION OF PROJECT	This project provides funding to replace the existing 1964, 60-year-old aluminum boat that does not meet the safety and rescue needs of our current water conditions.
---------------------------	---

2. NEED AND IMPACT OF PROJECT	The 1964 aluminum boat is not stable enough or designed to allow rescuers to pull patients/victims from the water into the boat. On average the BFD responds to 12 incidents annually that necessitate the response of a marine unit.
-------------------------------	---

3. CONSISTENCY WITH THE ADOPTED PLANS OR OTHER RELETATED PALNNING DOCS:	The intent of this project is to replace Marine 202, the 1964 aluminum boat with a stable inflatable rigid hull type boat with a 115HP outboard motor. The boat would be on trailer and would be deployed as needed into the river either above or below the dams. This project is part of the FD CIP equipment replacement program.
---	--

4. YEARS PREVIOUSLY ON THE BIDDICP; FUNDING RECVD IN PAST 5 YEARS (IF APPLICABLE)						
Reserve/Accrual	Year	FY2021	FY2022	FY2023	FY2024	FY2025
	Funding Recd	\$	\$	\$	\$	\$

5. NEW PERSONNEL, EQUIPMENT, OR SUPPLIES REQUIRED:	Boat, boat trailer, radios, GPS, other marine electronics, emergency lighting, search lighting.
--	---

6. HOW PROJECT ORIGINATED AND HOW COST ESTIMATES WERE OBTAINED:	This project originated with FD Command Staff's review of our current water rescue operational capabilities and level of safety for both the FD/Rescue/EMS providers and the victims and patients we are assisting.
---	---

7. ANY RELATED DEPARTMENT OR CITY PROJECTS:	N/A
---	-----

8. FINANCING POSSIBILITIES (BOND, GRANTS, FUND RAISE, COB, OTHER):	Funding Source	Agency	% Contribution	Dollar Amount	Notes
	COB	COB	100%	\$80,000	Fund through COB
	0	0	%	\$	0
	0	0	%	\$	0
	0	0	%	\$	0
	0	0	%	\$	0

9. JUSTIFICATION OF TIMING OF PROJECT AND SEGMENTS (IF APPLICABLE):	N/A
---	-----

10. OTHER INFO:	N/A
-----------------	-----

IMPLEMENTATION SCHEDULE (FISCAL YEARS)						
	FY2025	FY2026	FY2027	FY2028	FY2029	FUTURE
TOTAL PROJECT COST	\$	\$80,000	\$	\$	\$	\$
NON CITY SHARE	\$	\$	\$	\$	\$	\$
CITY SHARE	\$	\$80,000	\$	\$	\$	\$

ATTACH ON SEPARATE PAGE(S) ANY ADDITIONAL INFO (IF NEEDED)

